

***The Xerox
DocuPrint N24, N32, and
N40 Network Laser
Printers***

User Guide

Version 1.8

Copyright © 1998, 1999, Xerox Corporation. All Rights Reserved.

Copyright protection claimed includes all forms of matters of copyrightable materials and information now allowed by statutory or judicial law or hereinafter granted, including without limitation, material generated from the software programs which are displayed on the screen such as styles, templates, icons, screen displays, looks, etc.

XEROX®, The Document Company®, the stylized X, DocuPrint, and N24, N32, and N40 are trademarks of Xerox Corporation or its subsidiaries.

Adobe® and PostScript® are trademarks of Adobe Systems Incorporated.

PCL, HP, and LaserJet are trademarks of Hewlett-Packard Company. IBM is a trademark of International Business Machines Corporation. Microsoft, Microsoft Windows, Microsoft Word, MS, and MS-DOS are trademarks of Microsoft Corporation. Univers is a trademark of Linotype AG or its subsidiaries. WordPerfect is a trademark of Corel Corporation. Centronics is a trademark of Centronics Corporation. Macintosh and TrueType are trademarks of Apple Computer, Incorporated. OnPage is a trademark of COMPUTER:applications, Inc. All other product names are trademarks/tradenames of their respective owners.

PCL, *PCL5e*, and *PCL6* are trademarks of Hewlett-Packard Company. This printer contains an emulation of the Hewlett-Packard PCL command language, recognizes HP PCL commands, and processes these commands in a manner comparable with Hewlett-Packard LaserJet printer products.

This product includes an implementation of LZW licensed under U.S. Patent 4.558.302.

Notice

Specifications described in this publication are subject to change without notice. Use of some features may be limited by your hardware or software configuration. Contact your dealer, Xerox, or Xerox Limited for details.

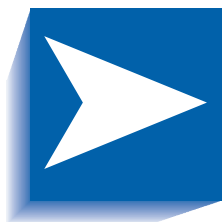



Table of Contents

Chapter 1	Getting Started	1-1
	<i>Introduction</i>	1-2
	<i>User Documentation Road Map</i>	1-3
	<i>Hardcopy User Documentation in the Box</i>	1-3
	<i>Your N40 CD Which Comes in the Box</i>	1-4
	<i>How Much of This Book Must I Read?</i>	1-6
	<i>Printer Components</i>	1-7
	<i>Installing Your Printer</i>	1-9
	<i>Printing a Configuration Sheet</i>	1-11
Chapter 2	Printer Management Software and Drivers	2-1
	<i>Using CentreWare DP with the DocuPrint N40</i>	2-2
	<i>DocuPrint N40 PCL Emulation Printer Drivers</i>	2-4
	<i>DocuPrint N40 PostScript Printer Drivers</i>	2-5
	<i>Driver Features</i>	2-6
	<i>Installing CentreWare DP and Drivers</i>	2-8
	<i>Configuring Your Drivers</i>	2-8
Chapter 3	Using the Control Panel	3-1
	<i>Control Panel Features</i>	3-2



	<i>The Display</i>	3-3
	Menu Options	3-4
Chapter 4	Paper Loading and Orientation	4-1
	Selecting Paper	4-2
	Storing Paper	4-5
	Loading Paper	4-6
	<i>Using Trays 1, 2, and 3 (if installed)</i>	4-7
	<i>Using Trays 4 and 5 in the 2,500 Sheet Feeder</i>	4-11
	<i>Using the 50 Sheet Bypass Feeder</i>	4-14
	<i>Using the 100 Envelope Feeder</i>	4-19
	Automatic Tray Switching	4-20
	<i>Paper Size/Type Mismatch</i>	4-21
	Duplex (Two-Sided) Printing	4-22
	<i>Print Orientation and Control Panel Settings</i>	4-23
Chapter 5	Clearing Jams and Jam Recovery	5-1
	Paper Jams	5-2
	<i>What Causes a Paper Jam?</i>	5-2
	<i>Clearing Paper Jams</i>	5-2
	<i>Clearing Area A (No Duplex Module)</i>	5-7
	<i>Clearing Area A (With Duplex Module)</i>	5-9
	<i>Clearing Area B</i>	5-12
	<i>Clearing Area C</i>	5-12
	<i>Clearing Area D</i>	5-13
	<i>Clearing Tray 5</i>	5-14
	<i>Clearing the Duplex Module</i>	5-15
Chapter 6	Replacing Your Toner Cartridge	6-1
	Replacing the Toner Cartridge	6-2
	<i>Standard Configuration</i>	6-3
	<i>Duplex Configuration</i>	6-6
	About the Maintenance Kit	6-9



Chapter 7	<i>Troubleshooting</i>	7-1
	<i>Diagnostic Message Display</i>	7-2
	<i>Printer Operation Problems</i>	7-3
Chapter 8	<i>References</i>	8-1
	<i>Further References</i>	8-2
Appendix A	<i>CE Declaration</i>	A-1

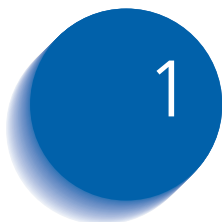

Getting Started

Introduction	1-2
User Documentation Road Map	1-3
<i>Hardcopy User Documentation in the Box</i>	1-3
<i>Your N40 CD Which Comes in the Box</i>	1-4
How Much of This Book Must I Read?	1-6
Printer Components	1-7
Installing Your Printer	1-9
Printing a Configuration Sheet	1-11

Introduction

This guide is for use with the Xerox DocuPrint N24, N32, and N40 family of printers.

Because most of the printer's features and functionality are shared by all three, this guide uses the generic name DocuPrint N40 when referring to these printers. And it refers to all features not found on the base printer as options.

It identifies two different configurations for the DocuPrint N40:

- The tabletop configuration.
- The console configuration (sitting on top of the optional 2,500 Sheet Feeder).

Samples of each configuration are shown later in this chapter; however, the figures throughout this guide may show either configuration when illustrating a feature or procedure.

User Documentation Road Map

Hardcopy User Documentation in the Box

There is user documentation provided to you for the N40 printer in several different places. This section will serve as an initial roadmap to that documentation.

You have received the following pieces of documentation:

1. An N24, N32, and N40 Quick Installation Guide (QIG) which shows you how to get the printer up and running.
2. This N24, N32, and N40 User Guide (UG) which provides you with the basic information needed to use your printer. (More detailed N40 user information is contained in your System Administrator Guide [SAG] on your N40 CD.)
3. The N24, N32, and N40 Quick Network Install Guide (QNIG) which briefly shows you how to connect your printer to a network in your specific environment. (More detailed Network/Environment information is contained in the Technical Information Guide [TIG] on your N40 CD.)

Your N40 CD Which Comes in the Box

This CD contains the following pieces of information:

1. The N24, N32, and N40 User Guide (UG)
2. The N24, N32, and N40 Quick Network Install Guide (QNIG)
3. The N24, N32, and N40 System Administrator Guide (SAG)
4. The 2,000 Sheet Finisher documentation
5. A procedure to upgrade your printer software.

The System Administrator Guide on this CD contains the following information should you require it:

1. The N24, N32, and N40 Quick Install Guide in Chapter 1
2. Installation instructions for N40 options in Appendix C
3. Installation instructions for the Toner Cartridge and the Maintenance Kit in Appendix B.

This document also contains a considerable amount of more detailed N40 user information.

The documents on the N40 CD are provided as PDF files with hyperlink capabilities which allow you to easily jump to and access different areas of the document. In addition, after you access the page or pages of information which you are looking for, you can then only print out the page(s) you need rather than print out the entire chapter or the manual. If you do not have a PDF reader on your system, you can also install one from this CD.



N40 printer drivers are also contained on the N40 product CD. The majority of Driver User Documentation is provided via the HELP files included with your drivers.

In addition to the N40 product CD, you are also provided with an N40 Printer Management Software CD. This CD contains various pieces of Xerox-provided Client Software as well as documentation for this software.

The N40 Product and Printer Management Software CDs are both provided with a CD Installation Booklet, packaged in the CD jewel case. You can also refer to the Read Me files on the CDs for more information.



Since these CDs provide so much important N40 information, please ensure that you save them and keep them in a safe place.

How Much of This Book Must I Read?

Use this book as a reference for:

- Getting Started (*Chapter 1: Getting Started*)
- Information about CentreWare and installing printer drivers (*Chapter 2: Printer Management Software and Drivers*)
- Instructions on using the Control Panel (*Chapter 3: Using the Control Panel*)
- Paper specifications, loading paper, and duplex printing (*Chapter 4: Paper Loading and Orientation*)
- Clearing Jams (*Chapter 5: Clearing Jams and Jam Recovery*)
- Replacing Your Toner Cartridge (*Chapter 6: Replacing Your Toner Cartridge*)
- Troubleshooting printing problems, if they occur (*Chapter 7: Troubleshooting*)
- Further References (*Chapter 8: References*)

Printer Components

The major components of the DocuPrint N40 are indicated in Figure 1.1 below.

Figure 1.1 Base printer components

Front View

- 1 Face-up Output Bin
- 2 Door A
- 3 50 Sheet Bypass Feeder
- 4 Door B
- 5 Face-down Output Bin
- 6 Power switch
- 7 Control Panel
- 8 Front cover
- 9 Paper Tray 1
- 10 Paper Tray 2

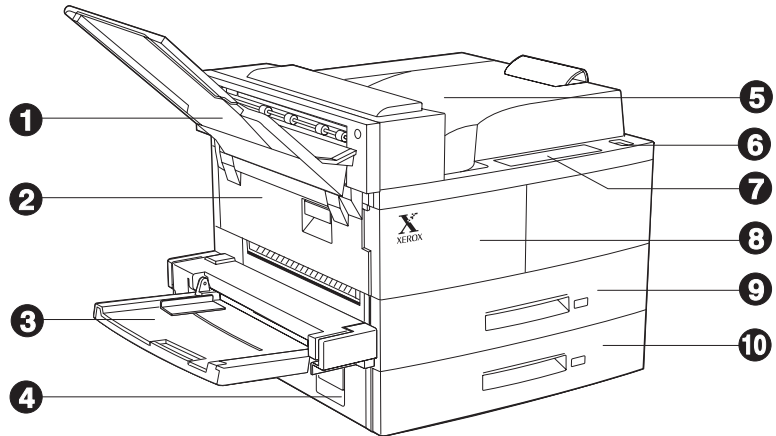

Rear View

- 1 Power receptacle
- 2 Hand grips
- 3 Controller Board with host/network interface ports.
- 4 Connectors for optional 2,500 Sheet Feeder, 10-bin Mailbox/Collator, Finisher and Duplex Module

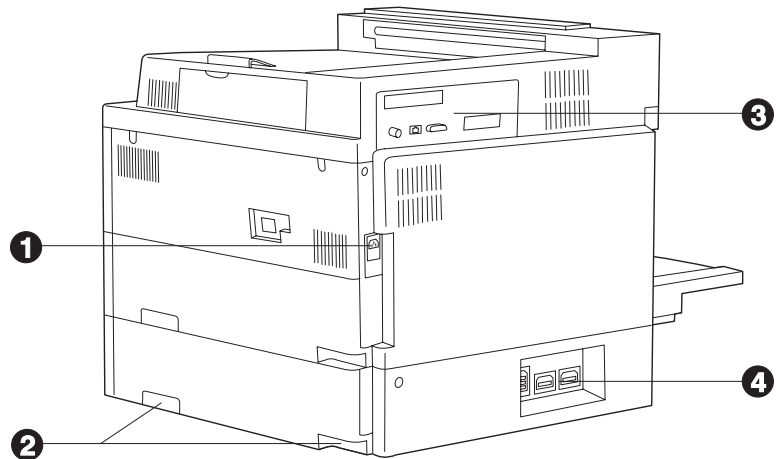



Figure 1.2 Console configuration with options

Front View

- 1 10-bin Mailbox/Collator
- 2 Face-up Output Bin
- 3 Duplex Module
- 4 100 Envelope Feeder
- 5 2,500 Sheet Feeder with Paper Trays 3, 4, and 5

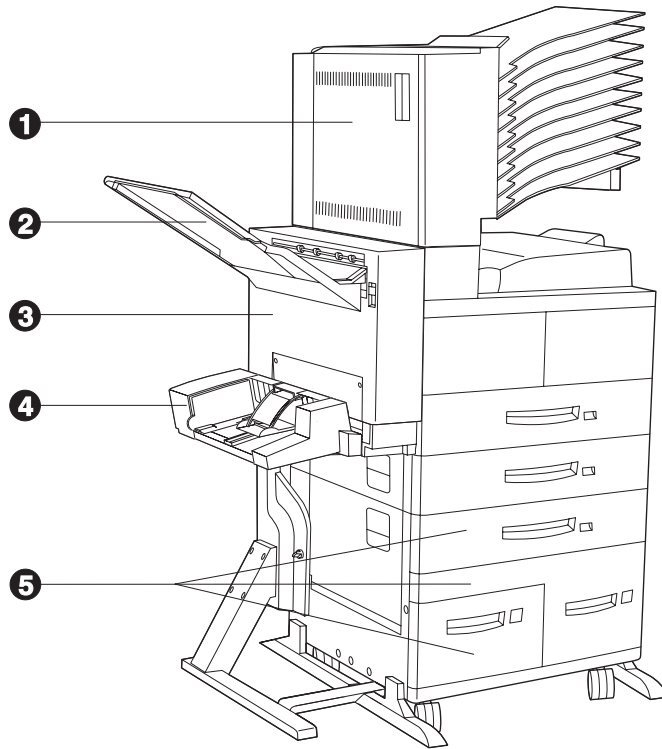
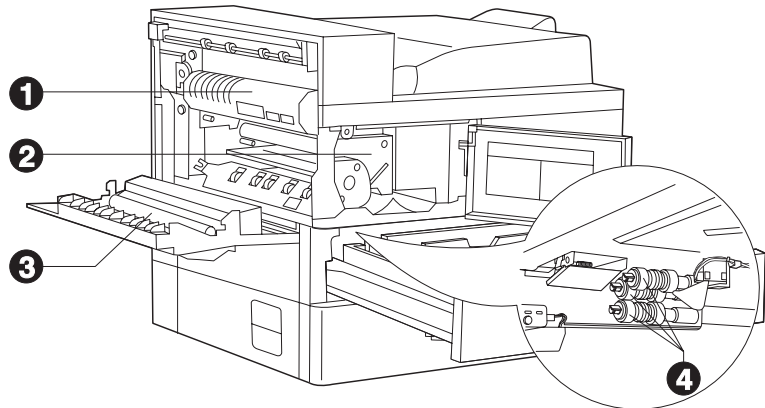

Figure 1.3 Customer replaceable components

Front View, Covers Open

- 1 Fuser
- 2 Toner Cartridge
- 3 Bias Transfer Roll (BTR)
- 4 Feedrolls



Installing Your Printer

There are other documents which will help you install your printer. The purpose of this section is simply to guide you to those documents (and sections of documents). The following documentation is available for installation assistance:

- The DocuPrint N40 System Administrator Guide (on the N40 product CD)
 - Chapter 1 shows how to initially install the DocuPrint N40.
 - Appendix B shows how to install the DocuPrint N40 Toner Cartridge and Maintenance Kit.
 - Appendix C shows how to install (and remove) the 2,500 Sheet Feeder, Duplex Module, 10-bin Mailbox/Collator, 100 Envelope Feeder, Hard Disk Drive, XNIC Network Interfaces, and memory SIMMs.
- The 2,500 Sheet Feeder, Duplex Module, 10-bin Mailbox/Collator and 100 Envelope Feeder have installation instructions in their boxes.
- The DocuPrint N40 itself comes with a Quick Installation Guide which guides you on your initial installation of the printer.
- The DocuPrint N40 Quick Network Install Guide provides guidance as to how to connect to the network within your specific environment.

- Chapter 2 of this guide provides some direction on how to install your DocuPrint N40 drivers and CentreWare software.
- More detailed information about installation can also be found in your CentreWare DP Users Manual, contained on the Printer Management Software CD that comes with your DocuPrint N40.



Please remember to save and store all your packing materials in a dry place so that you can retrieve these materials in the future should you be required to transport your DocuPrint N40 or its options.

Printing a Configuration Sheet

A very convenient way of both testing basic printer operation and determining how your printer is configured is to print a Configuration Sheet.

The following operator sequence from the DocuPrint N40 Control Panel will cause a Configuration Sheet to be printed:

1. Press **Menu Up**  or **Menu Down**  until you see:

Menus
Test Menu

on the Display.

2. Press **Item Up**  or **Item Down**  until you see:

Test Menu
Config Sheet

on the Display.

3. Press **Enter** . The Configuration Sheet will be printed.





2

Printer Management Software and Drivers

<i>Using CentreWare DP with the DocuPrint N40</i>	<i>2-2</i>
<i>DocuPrint N40 PCL Emulation Printer Drivers</i>	<i>2-4</i>
<i>DocuPrint N40 PostScript Printer Drivers</i>	<i>2-5</i>
<i>Driver Features</i>	<i>2-6</i>
<i>Installing CentreWare DP and Drivers</i>	<i>2-8</i>
<i>Configuring Your Drivers</i>	<i>2-8</i>

Using CentreWare DP with the DocuPrint N40

Xerox CentreWare DP is easy-to-use printer management software for Xerox printers. Through the ease of point-and-click navigation, you can install, connect, and configure the DocuPrint N40 on a network quickly and easily.

CentreWare DP provides network administrators with simplified setup procedures and effortless management of networked Xerox DocuPrint N40 printers.

Table 2.1 lists CentreWare DP key features and benefits. For more specific information about CentreWare DP use and operation, see “The CentreWare DP User Guide.”

Table 2.1 CentreWare DP key features and benefits

Feature	Benefit
Setup Wizard	Provides a step-by-step guide to get your printer quickly up and running on the network.
Advanced Setup	Provides a tool to service multiple file servers and queues.
Instant Status	Allows you to select a printer from the Printer List to see what that printer is doing at any given time.
Remote Configuration and Management	Allows you to do most configuration and monitoring tasks from your workstation.
Printer Upgrades	Allows you to upgrade your printer from your workstation.

CentreWare Sun OS/Solaris Services are also available to allow you to set up queues and also contain your N40 drivers for Sun OS/Solaris.

All the CentreWare software and documentation is on your Printer Management Software CD.

DocuPrint N40 PCL Emulation Printer Drivers

The base DocuPrint N40 supports the PCL printer drivers listed in Table 2.2. To take full advantage of all the printer's features when printing PCL jobs, install the appropriate DocuPrint N32 PCL emulation printer driver(s).

Table 2.2 DocuPrint N40 PCL Emulation printer drivers

Environment	Printer Driver
Windows	Windows 3.1x/ Windows 95 Windows NT 3.5.1 Windows NT 4.0

DocuPrint N40 PostScript Printer Drivers

The PostScript option supports the PostScript drivers listed in Table 2.3. To take full advantage of all the printer's features when printing PostScript jobs, install the appropriate DocuPrint N40 printer driver(s).

Table 2.3 DocuPrint N40 PostScript printer drivers

Environment	Printer Driver
Windows	Windows 3.1/ Windows 95 Windows NT 3.5.1 Windows NT 4.0
IBM OS/2	OS/2 Ver. 2.1 OS/2 WARP
Macintosh	System 6.x System 7.x
UNIX	Sun Solaris 2.4, 2.5, 2.5.1, 2.6 Sun OS 4.14 IBM AIX 4.1.x, 4.2.x HP-UX 9.x, 10.x

Driver Features

DocuPrint N40 drivers will support the following standard features:

- Input tray/Output bin selection
- Duplex selection
- Paper size, orientation and media
- Number of copies
- Collating

Table 2.4 on page 2-7 lists a general overview of features supported by the DocuPrint N40 drivers. Actual driver capabilities can be determined by invoking specific drivers.

Uni Drivers are universal drivers while custom devices are Xerox custom drivers.

Table 2.4 DocuPrint N40 driver features

Driver	Image Quality	Cover Sheets	Secure Printing	Edge-to-Edge	N-Up	Water-Mark	Fit-to-size ¹
PCL							
Windows 3.1x (Custom)	Y	Y	Y	Y	N	N	N
Windows 95 (Custom)	Y	Y	Y	Y	N	N	N
Windows NT 3.5.1 (Uni)	N	N	N	N	N	N	N
Windows NT 4.0 (Uni)	Y	N	N	N	Y	N	N
PS							
Windows 3.1x (Custom)	Y	Y	Y	Y	Y	Y	Y
Windows 95 (Custom)	Y	Y	Y	Y	Y	Y	Y
Windows NT 3.5.1 (Uni)	Y	N	N	N	N	N	N
Windows NT 4.0 (Custom)	Y	Y	Y	Y	Y	N	Y
MAC PS	N	N	N	N	N	N	N
OS/2 PS	N	N	N	N	N	N	N
UNIX PS							
Sun Solaris 2.4, 2.5, 2.5.1, 2.6	N	N	N	N	N	N	N
Sun OS 4.14	N	N	N	N	N	N	N
IBM AIX 4.1,x, 4.2.x	N	N	N	N	N	N	N
HP-UX 9.x, 10.x	N	N	N	N	N	N	N

¹ Page policy



Xerox custom drivers are recommended for use with the DocuPrint N40 since they will generally support the most DocuPrint N40 features.

Installing CentreWare DP and Drivers

Inside the cover of the DocuPrint N40 CDs, which come with your printer, are booklets which give you instructions on how to load both your DocuPrint N40 drivers and your DocuPrint N40 CentreWare software (depending on your software environment).

In addition, your System Administrator also has the capability to download drivers directly to your workstation.

Configuring Your Drivers

When you initially use any of your drivers, make sure to properly configure your driver by setting the correct DocuPrint N40 options displayed under the “PRINTER CONFIGURATION” tab in the drivers. You can determine which DocuPrint N40 options you have by printing a Configuration Sheet.

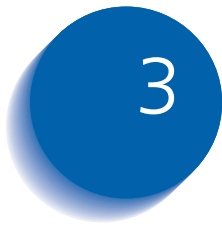

Using the Control Panel

<i>Control Panel Features</i>	3-2
<i>The Display</i>	3-3
<i>Menu Options</i>	3-4

Control Panel Features

The DocuPrint N40 Control Panel serves two purposes:

1. It displays information about the status of the printer (or the job in process).
2. It provides the means for changing printer settings and printer defaults to control how the DocuPrint N40 operates.

As shown in Figure 3.1, your printer's Control Panel will either have icons and text, or icons only.

Figure 3.1 DocuPrint N40 Control Panel

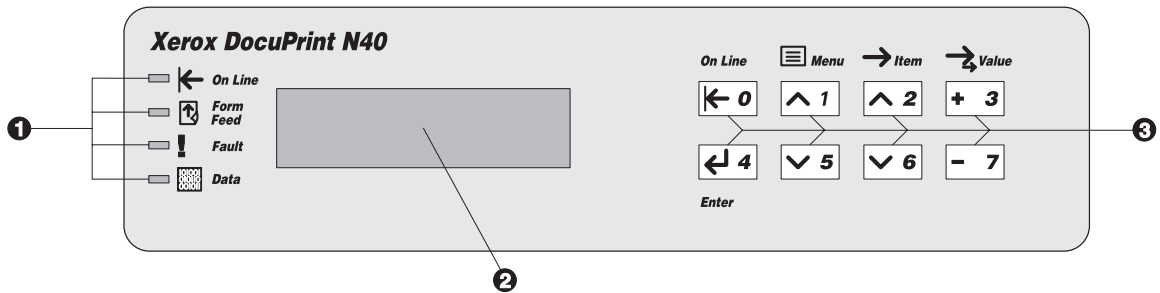

North America Control Panel
(Latin American machines will have translated version)

- 1 Indicator lights
- 2 Two-line by 16-character display
- 3 Control keys (8)

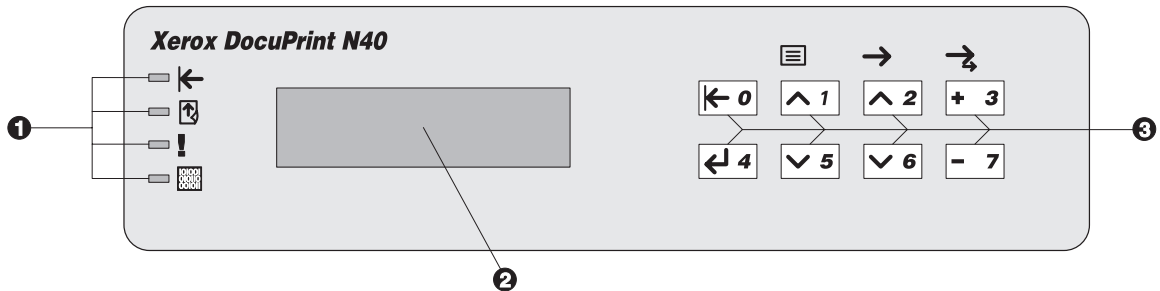

European Control Panel

The Display

The Control Panel's display performs two functions.

1. It informs you of printer status conditions, such as when toner is low, when a paper tray is empty, when a job is in process, and so on. For example, when you turn on the printer, you see the following message on the display:



Ready

This message appears whenever the printer is online and ready to accept print jobs. The display will also show:

Processing when processing data.

Waiting when waiting for more data.

2. It presents a hierarchy of menu options and settings to configure and control the printer.

For example, when you press **Menu Up**  or **Menu Down** , you will see the following two-line message on the display:

Menus

Item Menu (such as **Job Menu**)

See Chapter 3 of the DocuPrint N40 Systems Administrator Guide for information on the Menu system hierarchy.

Menu Options

Figure 3.2 on page 3-5 depicts a “Menu Map” for the DocuPrint N40. This map shows which variables are controlled by the DocuPrint N40 menus.

Details of all the available settings for the variables in these menus are contained in Chapter 3 of the *System Administrator Guide*.

In addition, Chapter 3 of the *System Administrator Guide* lists all the operations associated with the DocuPrint N40 Control Panel keys and lists the specific key processes which need to be executed to set any of these DocuPrint N40 variables.

Figure 3.2 DocuPrint N40 Menu Map

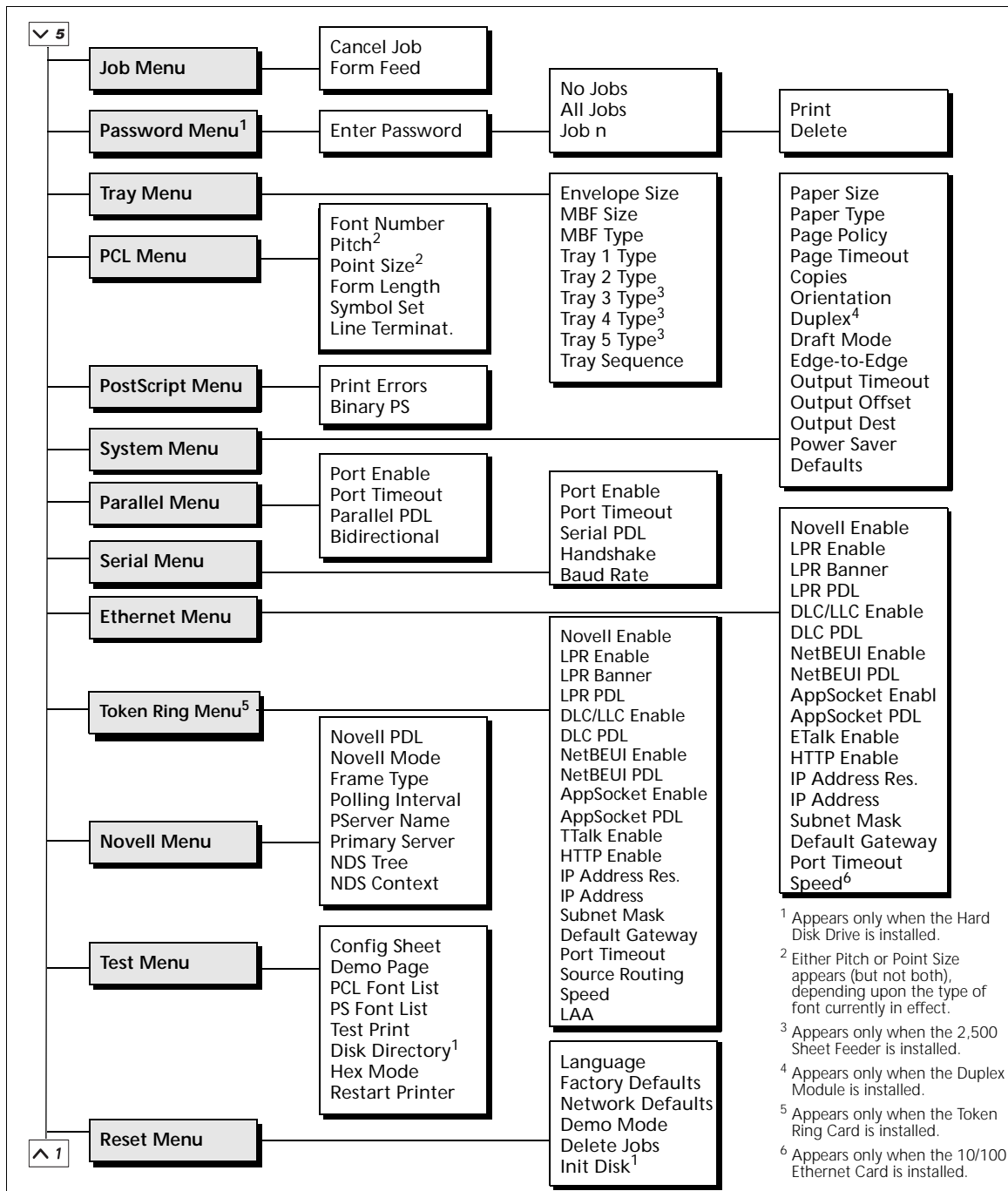





4

Paper Loading and Orientation

<i>Selecting Paper</i>	4-2
<i>Storing Paper</i>	4-5
<i>Loading Paper</i>	4-6
<i>Using Trays 1, 2, and 3 (if installed)</i>	4-7
<i>Using Trays 4 and 5 in the 2,500 Sheet Feeder</i>	4-11
<i>Using the 50 Sheet Bypass Feeder</i>	4-14
<i>Using the 100 Envelope Feeder</i>	4-19
<i>Automatic Tray Switching</i>	4-20
<i>Paper Size/Type Mismatch</i>	4-21
<i>Duplex (Two-Sided) Printing</i>	4-22
<i>Print Orientation and Control Panel Settings</i>	4-23

Selecting Paper

This chapter will help you understand what kinds of paper you can use with the DocuPrint N40 and also how to properly position paper in the different paper input trays so as to accomplish what you want with the DocuPrint N40.

Table 4.1 on page 4-4 lists the size paper, envelopes, and other print media you can use with all DocuPrint N40 input and output bins.

The DocuPrint N40 supports paper weights as follows:

- 17-28 lbs. (64-105 g/m²) via paper trays
- 17-57 lbs. (64-190 g/m²) A6 via the 50 Sheet Bypass Feeder
- 17-24 lbs. (64-90 g/m²) with duplex
- The optional 2,500 Sheet Feeder supports 18-24 lbs. (68-90 g/m²)

Using sizes other than those listed in Table 4.1, or paper not recommended for laser printers, may result in paper jams and print quality problems. The following media are unacceptable for use in the DocuPrint N40:

- Excessively thick or thin paper
- Paper that has already been printed on (preprinted letterhead is allowed)
- Wrinkled, torn, or bent paper
- Moist or wet paper
- Curled paper
- Paper with an electrostatic charge
- Glued paper

- Paper with special coating
- Paper unable to withstand a temperature of 150° C (302° F)
- Thermal paper
- Carbon paper
- Paper with paper fasteners, ribbons, tape, etc. attached
- Heavily textured paper
- Label stock with exposed backing sheets

Table 4.1 Acceptable media sizes and capacities for all DocuPrint N40 media trays

Media Size	Input					Output		
	Tray 1	Tray 2 Tray 3	Tray 4 Tray 5	50 Sheet Bypass Feeder	100 Envelope Feeder	Face- down Bin	Face- up Bin	10-bin Mailbox/ Collator
A3 297x420 mm	•	•		•		•	•	•
A4 210x297 mm	•	•	•	•		•	•	•
A5 148x210 mm	•			•		•	•	•
A6 105x148 mm				•		•	•	
Statement 5.5x8.5" 140x216 mm	•			•		•	•	•
Executive 7.25x10.5" 184x267 mm	•	•	•	•		•	•	•
Letter 8.5x11" 216x279 mm	•	•	•	•		•	•	•
Folio 8.5x13" 216x330 mm	•	•		•		•	•	•
Legal 8.5x14" 216x356 mm	•	•		•		•	•	•
Ledger 11x17" 279x432 mm	•	•		•		•	•	•
Envelopes COM-10 4.125x9.5" 105x241mm Monarch 3.87x7.5" 98x191mm DL 4.33x8.66" 110x220 mm C5 6.38x9.01" 162x229 mm				• • • •	• • • •	• • • •	• • • •	
Transparencies A4 210x297 mm Letter 8.5x11" 216x279mm	• •	Tray 2 Tray 2		• •		• •	• •	
Labels A4 210x297 mm Letter 8.5x11" 216x279mm				• •		• •	• •	
Capacity ¹	500	500/tray	1000/tray	50	100	500	200	100/bin

¹ Maximum capacity using 20 lb. (80 g/m²) stock.

For acceptable media sizes for use with the Duplex Module, see Table 4.2 on page 4-22.

Storing Paper

The DocuPrint N40's print quality is optimized when paper and other print media are properly stored. Proper storage ensures optimum print quality and trouble-free printer options.

- Store the paper on a flat surface, in a relatively low humidity environment.
- Avoid storing paper in such a way as to cause wrinkling, bending, curling, etc.
- Do not unwrap paper until you are ready to use it, and rewrap any paper you are not using.
- Do not expose paper to direct sunlight or high humidity.

Loading Paper

The DocuPrint N40 accepts paper from the following input trays:

- Trays 1 (500 sheets) and 2 (500 sheets) in the printer (see page 4-7)
- Tray 3 (500 sheets), the top tray in the optional 2,500 Sheet Feeder (also see page 4-7)
- Trays 4 (1,000 sheets), the lower left tray, and 5 (1,000 sheets), the lower right tray, in the optional 2,500 Sheet Feeder (see page 4-11)
- The 50 Sheet Bypass Feeder in the printer (see page 4-14)
- The optional 100 Envelope Feeder (see page 4-19)



- Do not attempt to load paper during printing into a tray that is currently in use.
- Do not overfill the trays.
- Use only the media specified in Table 4.1 on page 4-4 and avoid using the media listed on page 4-2.



The multiple trays of the DocuPrint N40 enable you to dedicate specific trays to specific sizes and types of paper. For example, if you have applications that require printing on letterhead, you can dedicate one of the printer's trays to that paper stock.

Using Trays 1, 2, and 3 (if installed)

Trays 1 and 2 in the printer, and Tray 3 in the optional 2,500 Sheet Feeder, hold up to 500 sheets of 20 lb. (80 g/m²) paper each. Refer to the section “*Selecting Paper*” (page 4-2) for acceptable paper sizes and weights.

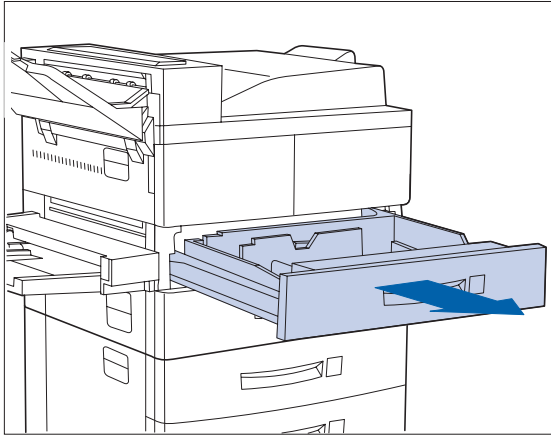

- 1 Pull out the tray (Tray 1 is shown above) until it stops.**

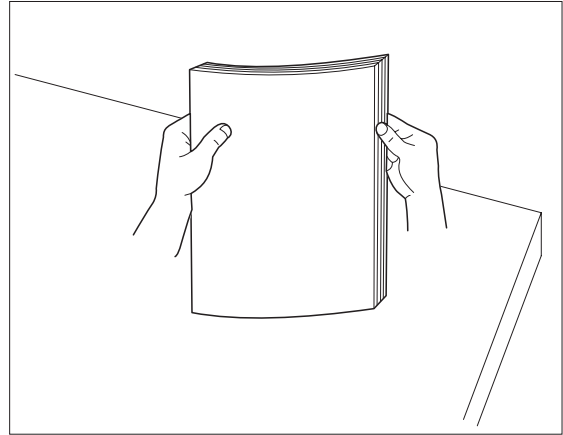

- 2 Prepare a stack of paper, making sure the tops of the sheets are aligned.**

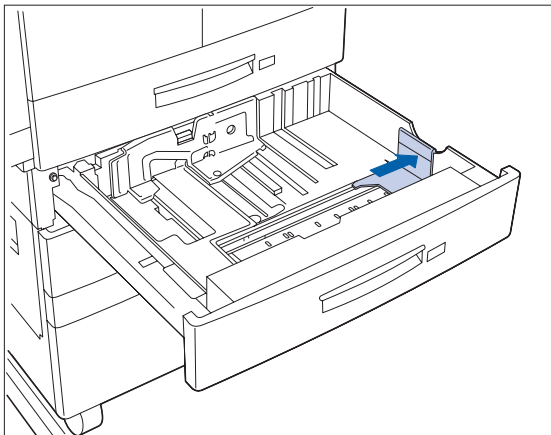

- 3 Gently lift up the width guide and slide it all the way until it stops.**

If you are replacing paper of the same size, skip to Step 5 on page 4-8.

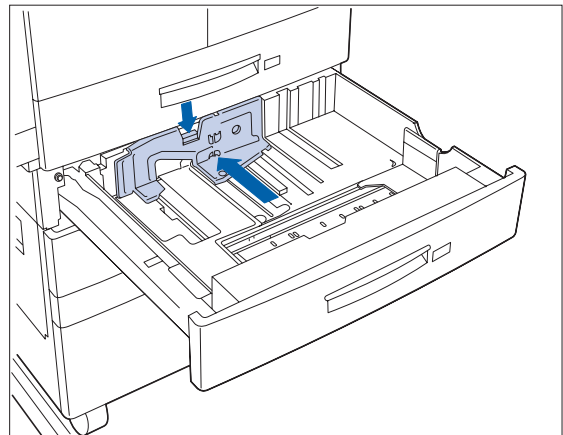

- 4 Press down the gray handle and slide the side guide all the way until it stops.**

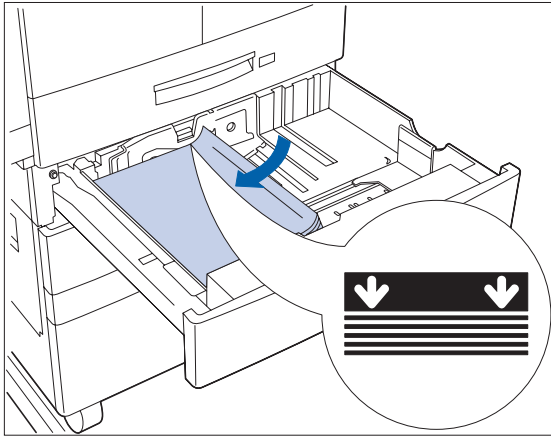

- 5** Place the paper in the tray, between the guides (see Figure 4.1 on page 4-9 and Figure 4.2 on page 4-10 for orientation).

 Do not stack paper above the indicated mark.

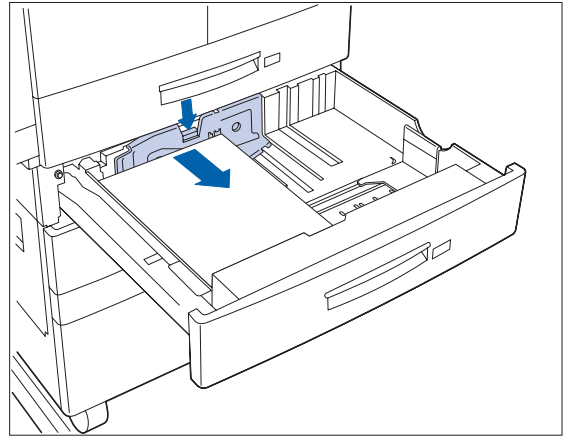

- 6** Adjust the side guide to the paper length.

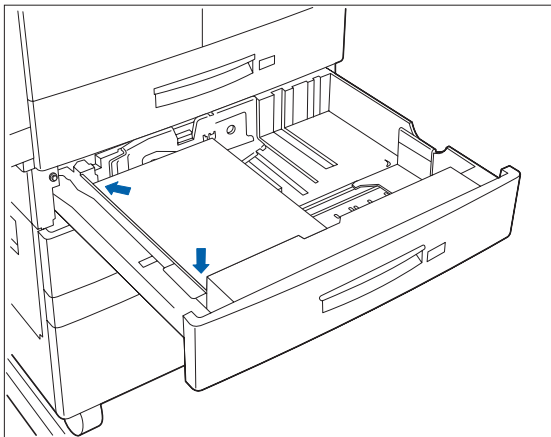

- 7** Align the edges of the paper stack.

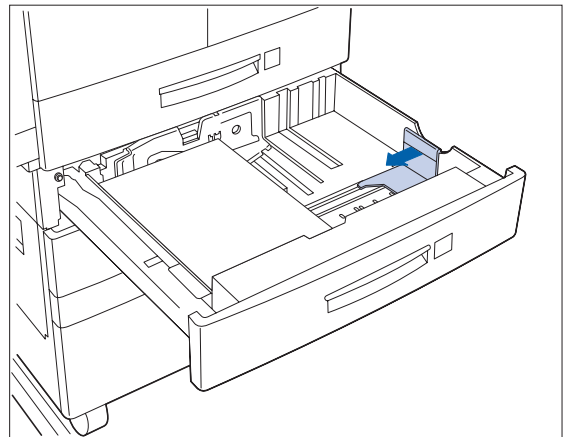

- 8** Adjust the width guide to the paper width.

 Make sure the guide is locked firmly in the guide hole on the bottom of the tray, and that both the side and width guides are set correctly for the size of paper you are using.

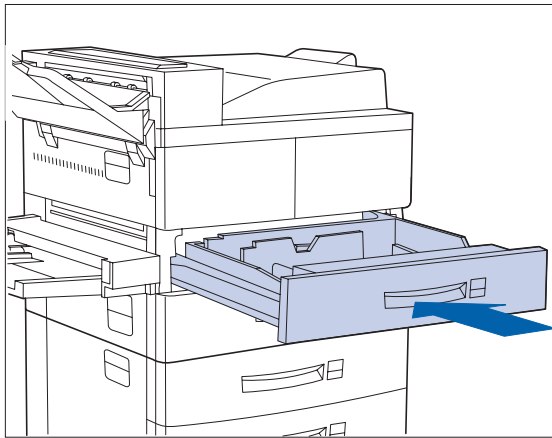

9 If changing paper size, you may want to insert the correct paper size label in the paper size slot on the front of the tray.

10 Push the tray all the way back into the printer until it latches.

Figure 4.1 Trays 1/2/3 paper orientation (long edge feed)

Top View

- 1 Duplex printing
- 2 Simplex printing

Load the following paper sizes with the long edge on the left (leading into the printer):

- Letter
- Statement
- Executive
- A4
- A5

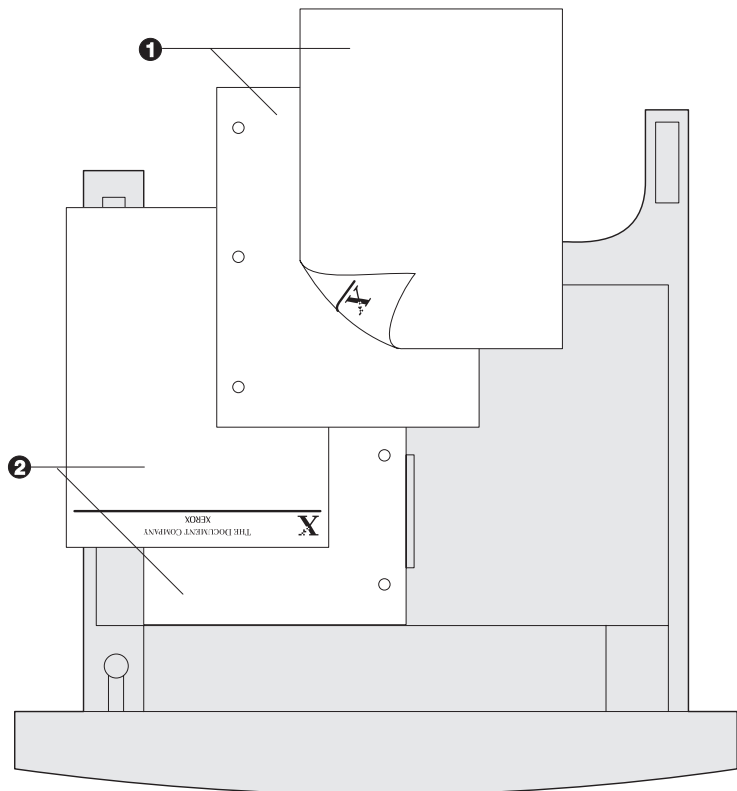

Figure 4.2 Trays 1/2/3 paper orientation (short edge feed)

Top View

- 1 Duplex printing
- 2 Simplex printing

Load the following paper sizes with the short edge on the left (leading into the printer):

- Legal
- Folio
- Ledger
- A3



The paper in this illustration looks like letter or A4 size paper, but it is not. The graphic is only a generic representation of the paper sizes listed above.

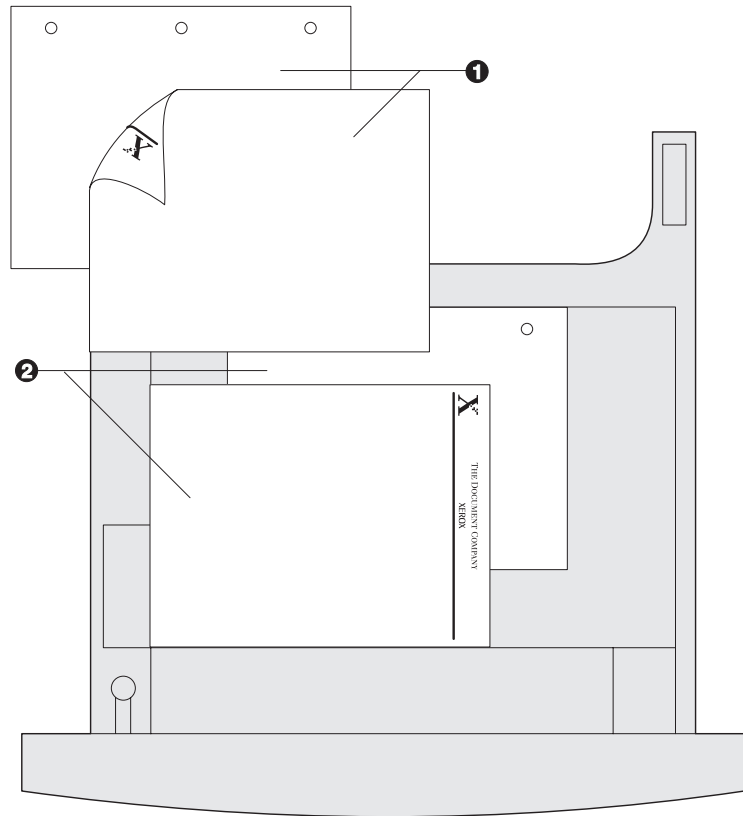

Using Trays 4 and 5 in the 2,500 Sheet Feeder

Trays 4 and 5 in the optional 2,500 Sheet Feeder hold up to 1,000 sheets of 20 lb. (80 g/m²) paper each (in A4, Letter and Executive size only). The following procedure uses Tray 4 as an example, but can be used for Tray 5 as well.

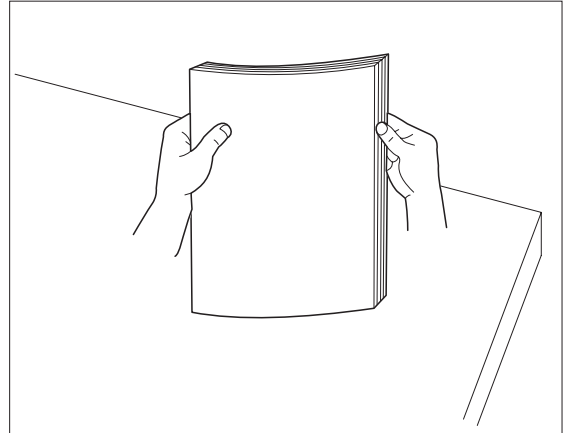
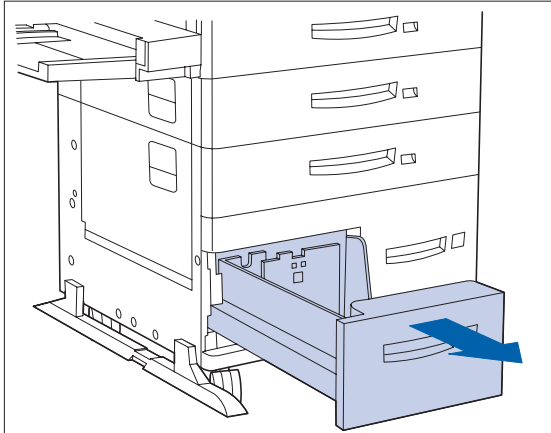

1 Pull out the tray until it stops.

2 Prepare a stack of paper, making sure the tops of the sheets are aligned.

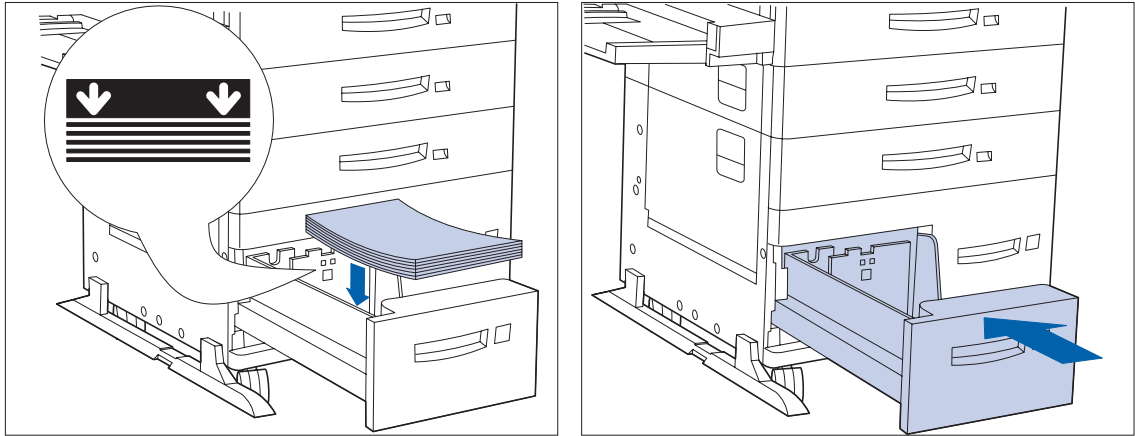

- 3 Place paper in the tray, against the left side (refer to Figure 4.3 on page 4-13 for orientation). Slide back the stop.**

 Do not stack paper above the indicated mark.

- 4 Push the tray back in.**

Figure 4.3 Trays 4 and 5 paper orientation

Top View Tray 4

- 1 Duplex printing
- 2 Simplex printing

Load the following sizes with the long edge on the left (leading into the printer):

Letter
Executive
A4

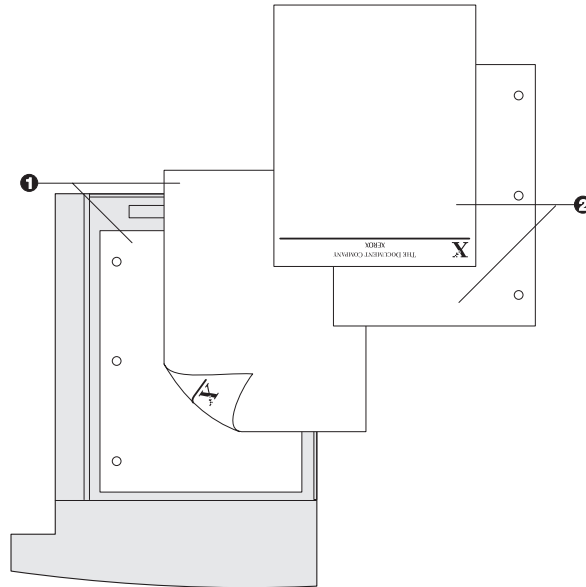
**Top View Tray 5**

- 1 Duplex printing
- 2 Simplex printing

Load the following sizes with the long edge on the left (leading into the printer):

Letter
Executive
A4

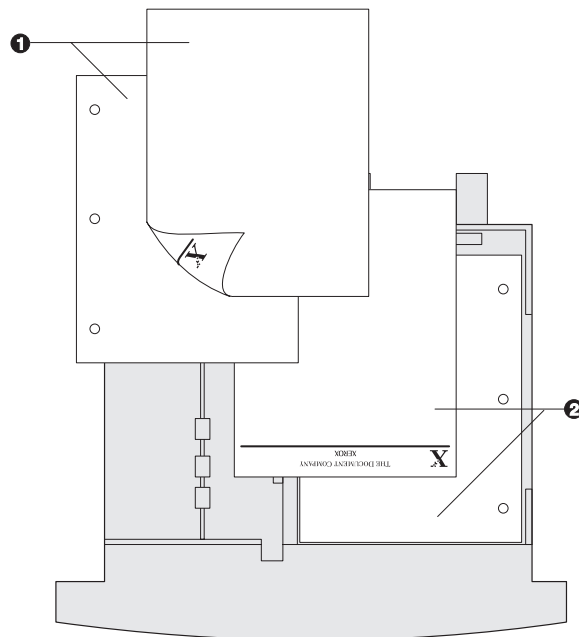

Using the 50 Sheet Bypass Feeder

The DocuPrint N40's 50 Sheet Bypass Feeder holds up to 50 sheets of 20 lb (80 g/m²) paper. Refer to the section "Selecting Paper" (page 4-2) for acceptable media sizes and weights.

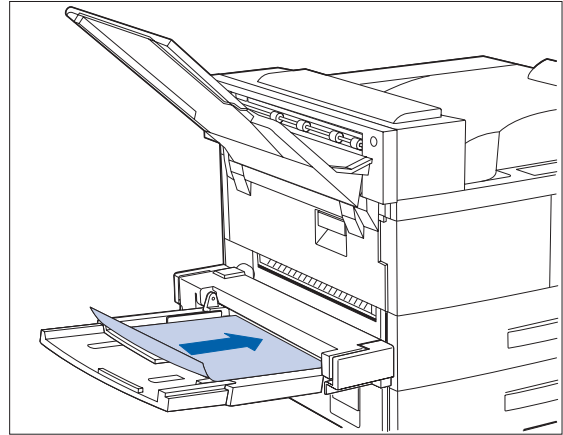
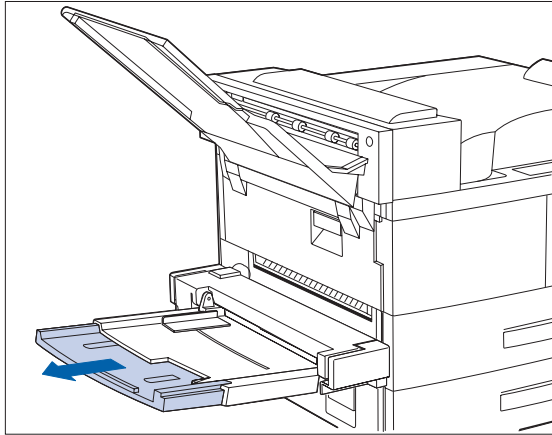

- 1** If necessary, pull out the extension tray to fit the length of paper to be used.
- 2** Place the paper along the right side of the Bypass Feeder (refer to Figure 4.4 on page 4-16 and Figure 4.5 on page 4-17 for paper orientation, and Figure 4.6 on page 4-18 for envelope orientation).

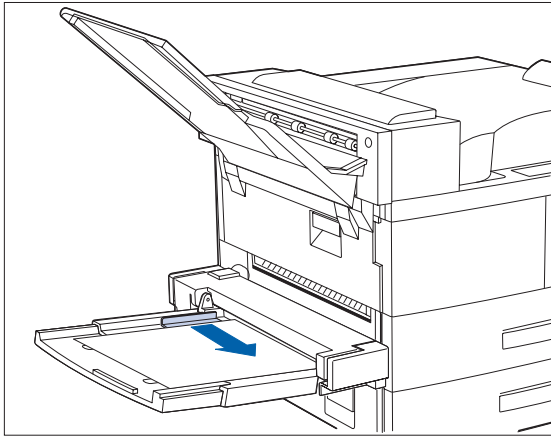

- 3** Push the paper guide to slightly touch the paper stack (to ensure contact with the paper sensor).

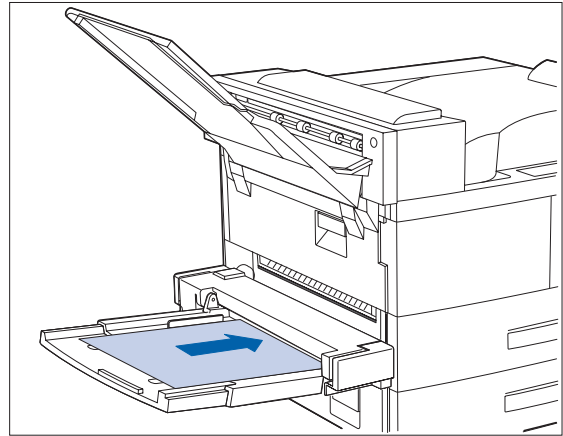

- 4** Push the paper as far as it can go into the printer.

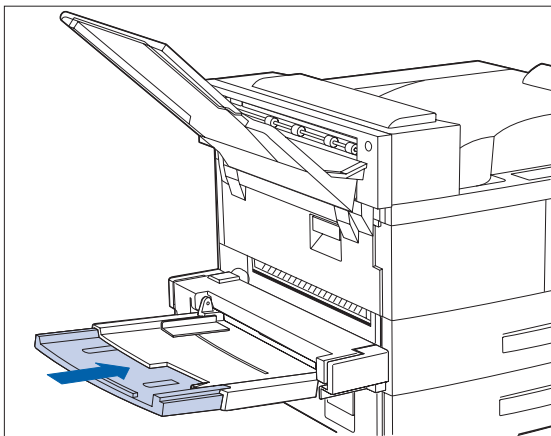

- 5** When finished printing from the Bypass Feeder, remove any remaining paper from the tray and push back the extension tray (if necessary), as paper will be fed from the Bypass Feeder if it is selected in the tray sequence.

Figure 4.4 50 Sheet Bypass Feeder paper orientation (long edge feed)

Top View

- 1** Simplex printing
- 2** Duplex printing

Load the following paper sizes with the long edge leading into the printer:

- Letter
- Statement
- Executive
- A4
- A5

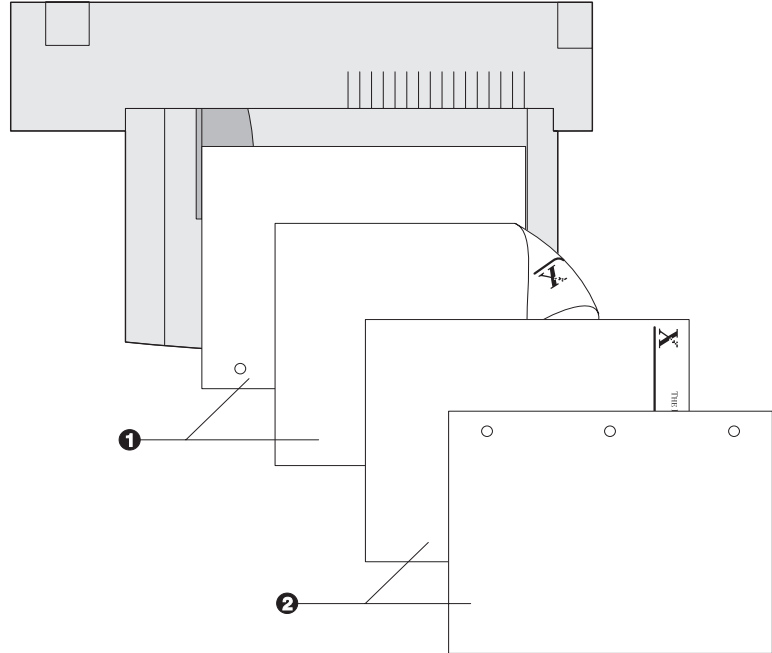

Figure 4.5 50 Sheet Bypass Feeder paper orientation (short edge feed)

Top View

- 1** Simplex printing
- 2** Duplex printing

Load the following paper sizes with the short edge leading into the printer:

- Legal
- Folio
- Ledger
- A3
- A6

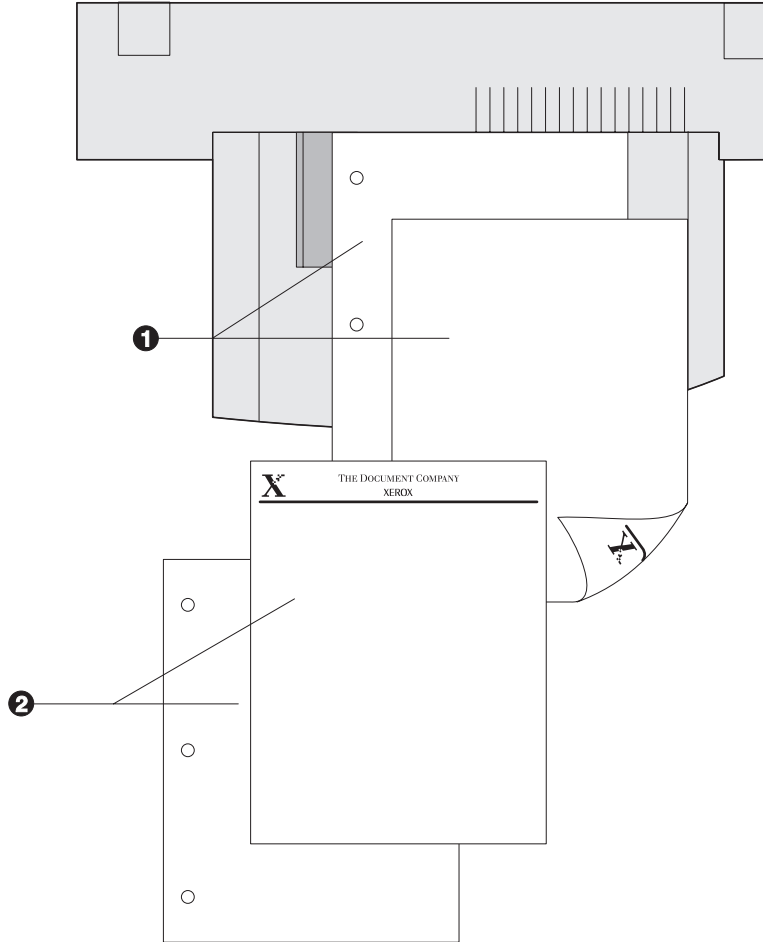
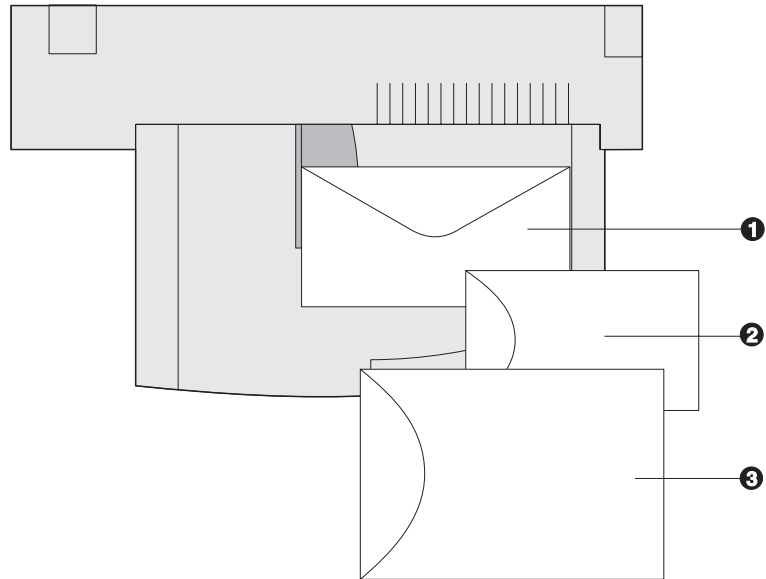

Figure 4.6 50 Sheet Bypass Feeder envelope orientation¹

Top View

- 1 Envelope
- 2 DL Envelope
- 3 C5 Envelope



¹ Some PostScript applications require that the envelopes be loaded with the return address corner on the right side of the stack and leading as the envelopes go into the printer. Test your application for proper orientation.

Using the 100 Envelope Feeder

The 100 Envelope Feeder is an optional paper handling device available for the DocuPrint N40. Refer to Table 4.1 on page 4-4 for acceptable envelope sizes.

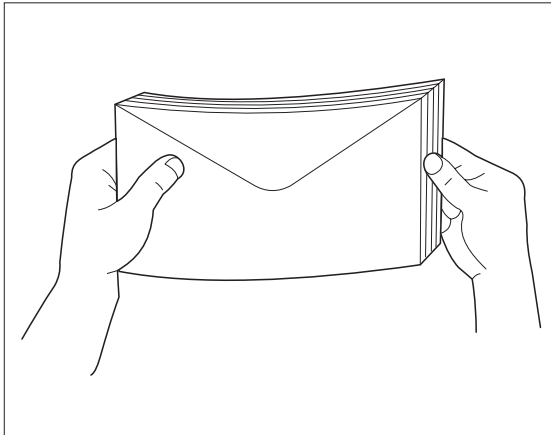

- 1 Prepare a stack of envelopes, making sure all flaps are closed and the envelopes are not stuck together.**

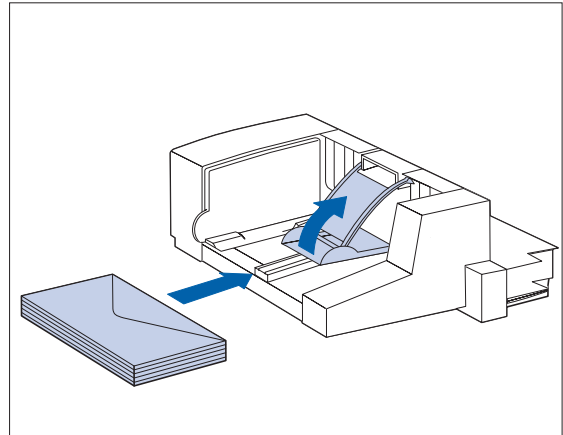

- 2 Lift the envelope stopper and insert the stack with the flap-side up and the long edges leading into the printer.**

- 3 Slide the side guide so that it lightly touches the edges of the envelope stack.**

! To avoid paper jams, do not stack envelopes above the paper limit mark, and do not attempt to add envelopes while printing.

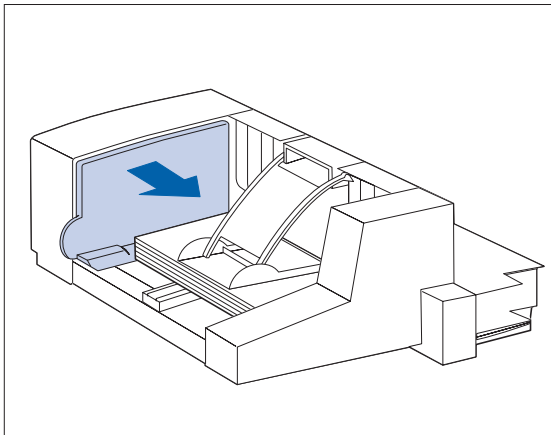

Automatic Tray Switching

Automatic tray switching, available for both PCL and PostScript jobs, enables you to group two or more input trays together into one logical tray, and in a specific order in which the trays will be searched to satisfy an input request. Tray switching is useful for:

- Increasing paper capacity.

When the current paper tray runs out of paper, the printer automatically switches to the next tray in the sequence, provided the paper size and type in the next tray is the same size and type as that in the current tray.

- Searching for the correct paper size and type.

If the paper size and type specified in your software application does not match the size paper loaded in the current paper tray, the printer automatically searches the next tray in the sequence for a paper size and type that matches.

- Loading paper in one tray while printing from another tray (filling an empty tray while printing).

Tray switching is made possible via the Tray Sequence item in the Control Panel's Tray Menu. It enables grouping of Trays 1 and 2 in the printer, the 50 Sheet Bypass Feeder, and Trays 3, 4, and 5 in the 2,500 Sheet Feeder (if installed) into a variety of sequence combinations. Tray switching can also be turned off.



The 50 Sheet Bypass Feeder is referred to as the MBF (for Multiple Bypass Feeder) in the Control Panel's Tray Sequence settings.



Paper Size/Type Mismatch

Paper size/type mismatch occurs when the requested size is not available in the printer. This can be caused by running out of paper in a tray that is configured for the requested paper, or by requesting a paper that is not configured in the printer. The printer goes off-line under paper mismatch conditions. It automatically returns on-line and continues printing after the paper mismatch condition is resolved.

If a tray is configured for the requested paper, but the tray is out of paper, the display prompts you to load the requested paper (size and type) in the appropriate tray. After the tray is loaded, printing continues.

If the request is for paper that is not configured in the printer, you are prompted to load the requested paper in the first tray of the Tray Sequence setting.

If you do not want to load paper in the first tray of the Tray Sequence setting, two options are available:

- One of the trays may be loaded with the requested size paper and reconfigured via the Tray Menu to match the requested paper type.
- **Value Up**  or **Value Down**  may be pressed to scroll through all the trays, displaying the size and type paper in each tray. If one of these alternate papers is acceptable, pressing **Enter**  will cause printing to continue on the new paper. Trays are searched in the order specified in the Tray Sequence setting.

Duplex (Two-Sided) Printing

Once the optional Duplex Module is installed and Duplex printing is enabled in the Control Panel, you can print two-sided (duplex) jobs. Duplex printing can also be enabled from your printer driver.

Use only the size paper listed in Table 4.2 for two-sided jobs. Do not use envelopes, card stock, transparencies, or label paper for duplex jobs.

Table 4.2 Paper sizes that can be used with the Duplex Module

Paper Size	Weight
A3 (297 x 420 mm)	17 lb. (64 g/m ²) to 24 lb. (90 g/m ²)
A4 (210 x 297 mm)	17 lb. (64 g/m ²) to 24 lb. (90 g/m ²)
A5 (148 x 210 mm)	17 lb. (64 g/m ²) to 24 lb. (90 g/m ²)
Statement (5.5 x 8.5" / 140 x 216 mm)	17 lb. (64 g/m ²) to 24 lb. (90 g/m ²)
Executive (7.25 x 10.5" / 216 x 279 mm)	17 lb. (64 g/m ²) to 24 lb. (90 g/m ²)
Letter (8.5 x 11" / 216 x 279 mm)	17 lb. (64 g/m ²) to 24 lb. (90 g/m ²)
Folio (8.5 x 13" / 216 x 330 mm)	17 lb. (64 g/m ²) to 24 lb. (90 g/m ²)
Legal (8.5 x 14" / 216 x 356 mm)	17 lb. (64 g/m ²) to 24 lb. (90 g/m ²)
Ledger (11 x 17" / 279 x 432 mm)	17 lb. (64 g/m ²) to 24 lb. (90 g/m ²)

Refer to Figure 4.1 on page 4-9 and Figure 4.4 on page 4-16 for the proper orientation of drilled paper and letterhead when printing duplex.

Print Orientation and Control Panel Settings

To ensure that duplex jobs print in the proper orientation, set the Duplex option (in the System Menu) to the appropriate setting (see Figure 4.7). The Duplex settings for both PCL and PostScript are as follows:

Duplex = Off

Duplex = Short Edge, or

Duplex = Long Edge

Figure 4.7 Duplex binding orientation and Control Panel menu settings

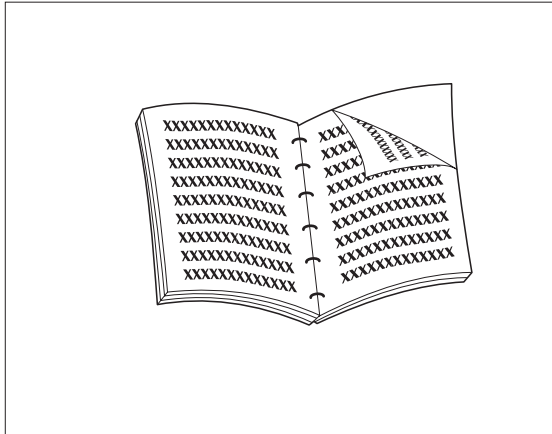

Portrait Orientation: Set Duplex to *Long Edge*.

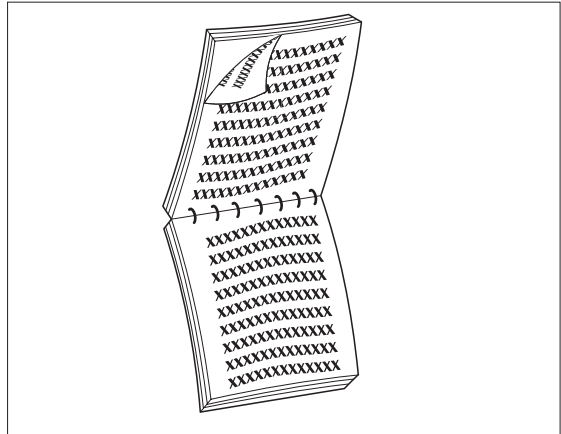

Portrait Orientation: Set Duplex to *Short Edge*.

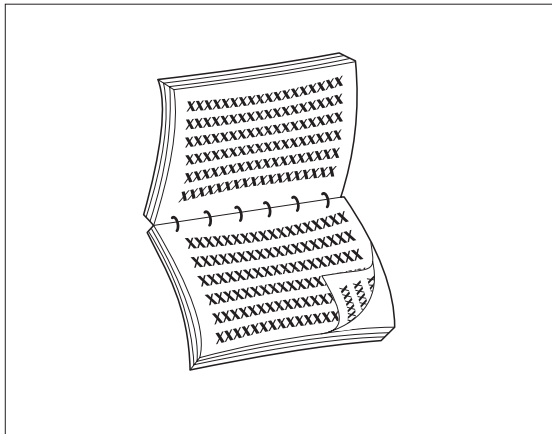

Landscape Orientation: Set Duplex to *Long Edge*.

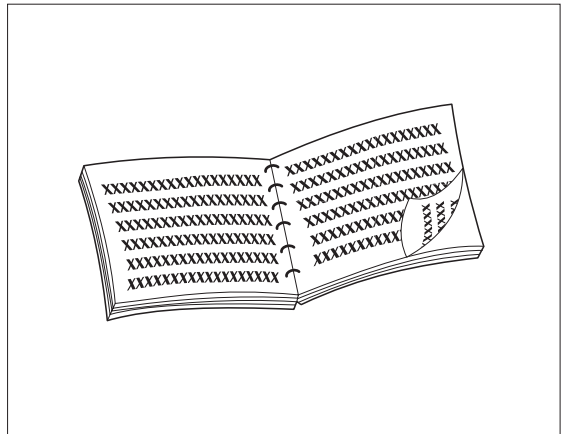

Landscape Orientation: Set Duplex to *Short Edge*.





Clearing Jams and Jam Recovery

Paper Jams	5-2
<i>What Causes a Paper Jam?</i>	5-2
<i>Clearing Paper Jams</i>	5-2
<i>Clearing Area A (No Duplex Module)</i>	5-7
<i>Clearing Area A (With Duplex Module)</i>	5-9
<i>Clearing Area B</i>	5-12
<i>Clearing Area C</i>	5-12
<i>Clearing Area D</i>	5-13
<i>Clearing Tray 5</i>	5-14
<i>Clearing the Duplex Module</i>	5-15

Paper Jams

Your DocuPrint N40 printer has been designed to provide reliable, trouble-free operation. However, you may experience an occasional paper jam.

When the printer detects a misfeed or a paper jam, the printing process is halted and a Control Panel message is displayed.

After the paper jam has been cleared, the printer will resume operation to complete the print job. The pages in the print engine will be reprinted when the jam is cleared and printing resumes.

What Causes a Paper Jam?

Paper jams occur most often when:

- The paper stock does not meet specification. See *Chapter 4: Paper Loading and Orientation*.
- The paper stock is in poor condition.
- The printer needs cleaning.
- Printer parts are worn and need to be replaced.

Clearing Paper Jams

Table 5.1 lists the types of paper jams that may occur. If you see a Control Panel message that indicates a paper jam, find the message in the left-hand column and perform the accompanying steps to clear the paper jam.



Be careful not to touch any of the components inside the printer when removing jammed paper. They may be very hot.

Table 5.1 Paper jam messages

Message	Description/Corrective Action
Clear Area A Clear Env/Bypass	A paper jam has occurred in Area A. ACTION: Clear the Envelope Feeder or the Bypass Feeder. Then reseal Tray 1.
Clear Area A Reset Tray 1	A paper jam has occurred in Area A. Use one of the following procedures to clear Area A: <ul style="list-style-type: none"> • “Clearing Area A (No Duplex Module)” (page 5-7) • “Clearing Area A (No Duplex Module)” (page 5-7). Then reseal Tray 1.
Clear Area B Reset Tray 2	A paper jam has occurred in Area B. Use the procedure: <ul style="list-style-type: none"> • “Clearing Area B” (page 5-12). Then reseal Tray 2.
Clear Area C Reset Tray 4	A paper jam has occurred in Area C. Use the procedure “Clearing Area C” (page 5-12) to clear Area C. Then reseal Tray 4.
Clear Area A,B Reset Tray 2	A paper jam has occurred in Areas A and B. Use one of the following procedures to clear Area A: <ul style="list-style-type: none"> • “Clearing Area A (No Duplex Module)” (page 5-7) • “Clearing Area A (With Duplex Module)” (page 5-9). Then use the procedure “Clearing Area B” (page 5-12) to clear Area B. Then reseal Tray 2.

Table 5.1 Page 1 of 4

Table 5.1 Paper jam messages (continued)

Message	Description/Corrective Action
Clear Area C Reset Tray 5	A paper jam has occurred in Area C. Use the procedure "Clearing Area C" (page 5-12) to clear Area C. Then reseal Tray 5.
Clear Area A,B Reset Tray 3	A paper jam has occurred in Areas A and B. Use one of the following procedures to clear Area A: <ul style="list-style-type: none"> "Clearing Area A (No Duplex Module)" (page 5-7) "Clearing Area A (With Duplex Module)" (page 5-9). Then use the procedure "Clearing Area B" (page 5-12) to clear Area B. Then reseal Tray 3.
Clear Area A,B,C Reset Tray 4	A paper jam has occurred in Areas A, B, and C. Use one of the following procedures to clear Area A: <ul style="list-style-type: none"> "Clearing Area A (No Duplex Module)" (page 5-7) "Clearing Area A (With Duplex Module)" (page 5-9). Then use the procedure "Clearing Area B" (page 5-12) to clear Area B. Then use the procedure "Clearing Area C" (page 5-12) to clear Area C. Then reset Tray 4.
Clear Area A,B,C Reset Tray 5	A paper jam has occurred in Areas A, B, and C. Use one of the following procedures to clear Area A: <ul style="list-style-type: none"> "Clearing Area A (No Duplex Module)" (page 5-7). "Clearing Area A (With Duplex Module)" (page 5-9). Then use the procedure "Clearing Area B" (page 5-12) to clear Area B. Then use the procedure "Clearing Area C" (page 5-12) to clear Area C. Then reset Tray 5.

Table 5.1 Page 2 of 4

Table 5.1 Paper jam messages (continued)

Message	Description/Corrective Action
Paper Jam Clear Area A	A paper jam has occurred in Area A. Use one of the following procedures: <ul style="list-style-type: none"> • “Clearing Area A (No Duplex Module)” (page 5-7). • “Clearing Area A (With Duplex Module)” (page 5-9).
Paper Jam Clear Area A,B	A paper jam has occurred in Areas A and B. First use one of the following procedures to clear Area A: <ul style="list-style-type: none"> • “Clearing Area A (No Duplex Module)” (page 5-7). • “Clearing Area A (With Duplex Module)” (page 5-9). Then use the procedure “Clearing Area B” (page 5-12) to clear Area B.
Paper Jam Clear Area A,B,C	A paper jam has occurred in Areas A, B, and C. First use one of the following procedures to clear Area A: <ul style="list-style-type: none"> • “Clearing Area A (No Duplex Module)” (page 5-7). • “Clearing Area A (With Duplex Module)” (page 5-9). Then use the procedure “Clearing Area B” (page 5-12) to clear Area B. Then use the procedure “Clearing Area C” (page 5-12) to clear Area C.
Paper Jam Clear Area B	A paper jam has occurred in Area B. Use the procedure “Clearing Area B” (page 5-12).
Paper Jam Clear Area B,C	A paper jam has occurred in Areas B and C. First use the procedure “Clearing Area B” (page 5-12) to clear Area B. Then use the procedure “Clearing Area C” (page 5-12) to clear Area C.
Paper Jam Clear Area C	A paper jam has occurred in Area C (2,500 Sheet Feeder). Use the procedure “Clearing Area C” (page 5-12).

Table 5.1 Page 3 of 4

Table 5.1 Paper jam messages (continued)

Message	Description/Corrective Action
Paper Jam Clear Area D	A paper jam has occurred in Area D (Mailbox/Collator). Use the procedure <i>"Clearing Area D"</i> (page 5-13).
Paper Jam Clear Duplex Unit	A paper jam has occurred in the Duplex Module. Use the procedure <i>"Clearing the Duplex Module"</i> (page 5-15).
Paper Jam Clear Env Feeder	The printer cannot feed from the Envelope Feeder. ACTION: Open the Envelope Feeder and remove any jammed envelopes.
Paper Jam Clear Tray 5	A paper jam has occurred in Tray 5 (2,500 Sheet Feeder). ACTION: Open Tray 5 and remove jammed paper. Refer to the section <i>"Clearing Paper Jams"</i> (page 5-2) and the procedure <i>"Clearing Tray 5"</i> (page 5-14).

Table 5.1 Page 4 of 4

Clearing Area A (No Duplex Module)

Follow the procedure below to clear a paper jam from Area A when the Control Panel display reads **Clear Area A** and the printer does not have the Duplex Module installed.

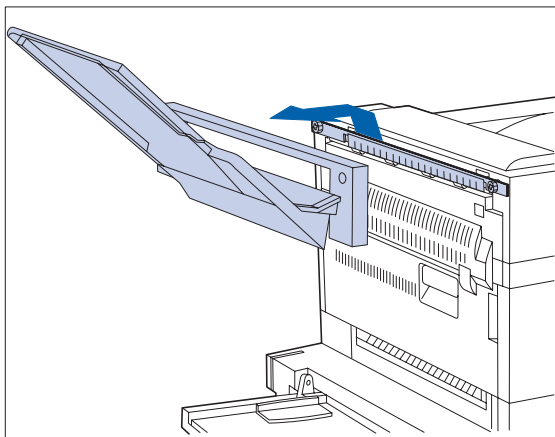

- 1 Remove the Face-up Bin by lifting it up and out.**

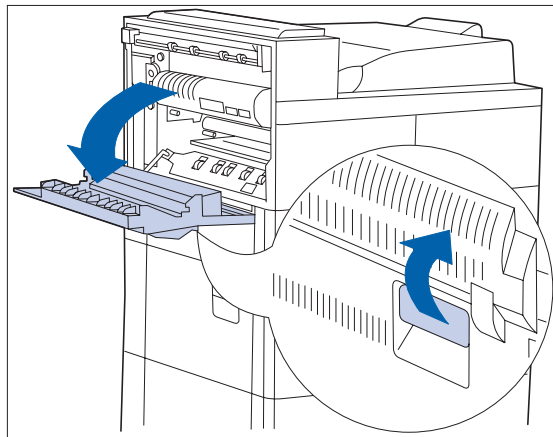

- 2 Open Door A.**

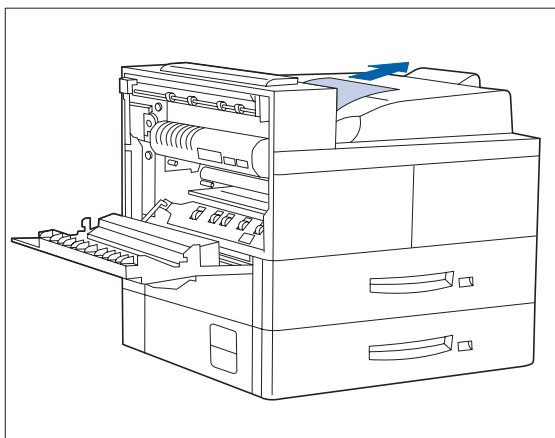

- 3 Remove any jammed paper.**

A If the leading edge of the paper is already in the Face-down Bin, gently pull out the paper until it is completely removed.

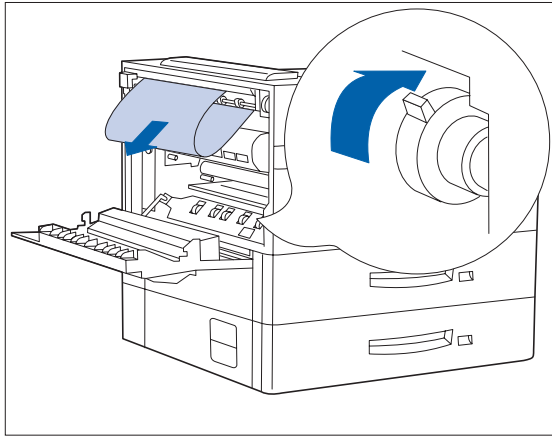

B If the paper is jammed in the Fuser area, remove it carefully without touching the Fuser. If it becomes difficult to pull out the paper, locate the green knob— at the same time, press it in and turn it until the paper is adequately out and easy to pull.

! Never touch the Fuser area (where a label indicating high temperature is located).

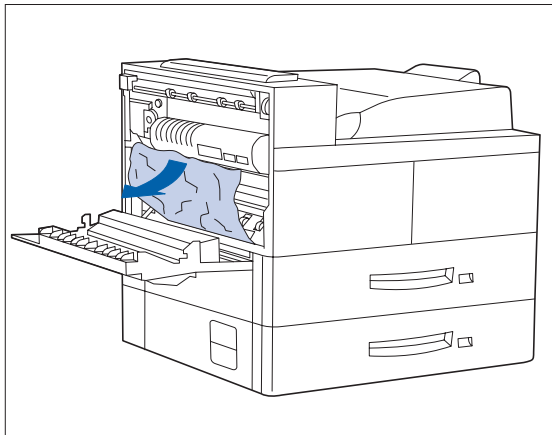

C If the paper jammed in Area A is below the Fuser, remove it by gently pulling it away from the printer.

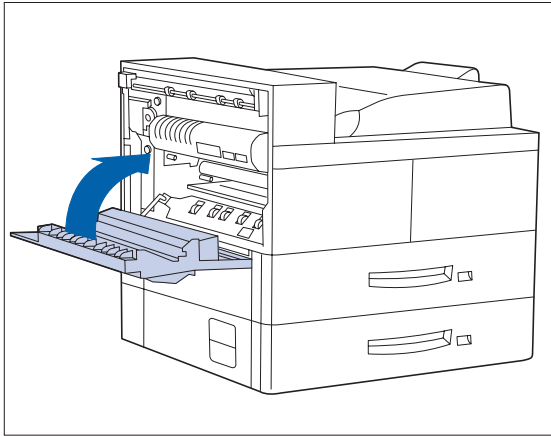

- 4 Close Door A, then reattach the Face-up Bin.**

 *If the Control Panel message indicates an Area B jam, continue to the section “Clearing Area B” (page 5-12).*

Clearing Area A (With Duplex Module)

Follow the procedure below to clear a paper jam from Area A when the Control Panel display reads **Clear Area A** and there is a Duplex Module installed on the printer.

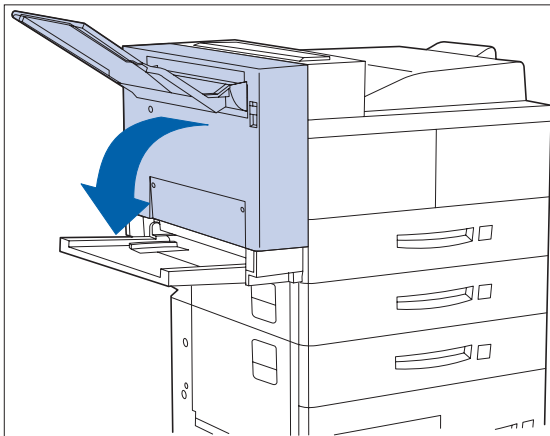

- 1 Remove any paper from the Face-up Tray, then open the Duplex Module.**

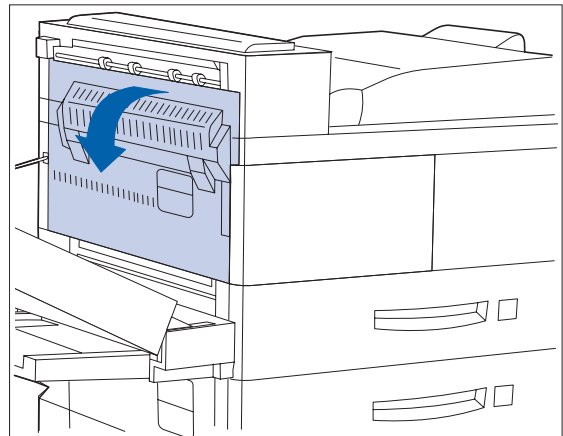

- 2 Open Door A.**

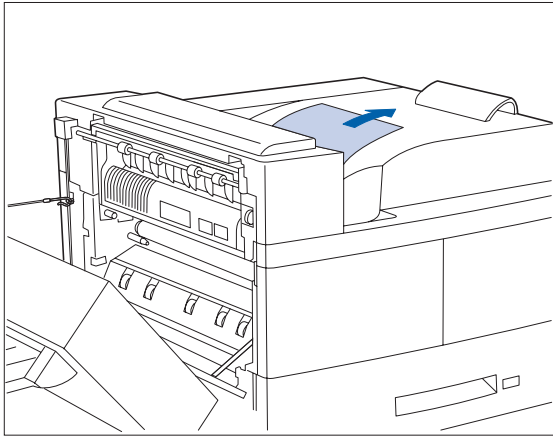

3 Remove any jammed paper:

A If the leading edge of the paper is already in the Face-down Bin, gently pull out the paper until it is completely removed.

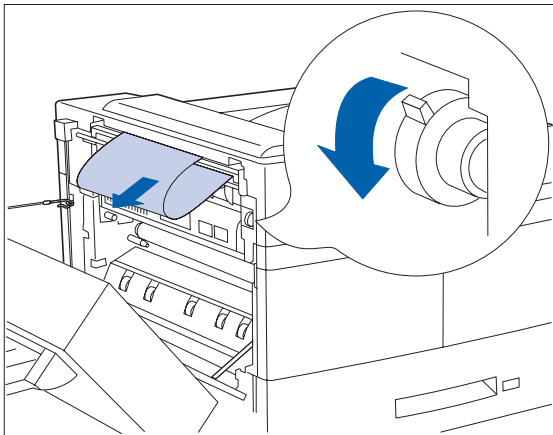

B If the paper is jammed in the Fuser area, remove it carefully without touching the Fuser. If it becomes difficult to pull out the paper, locate the green knob— at the same time, press it in and turn it until the paper is adequately out and easy to pull.

! Never touch the heater area (where a label indicating high temperature is located).

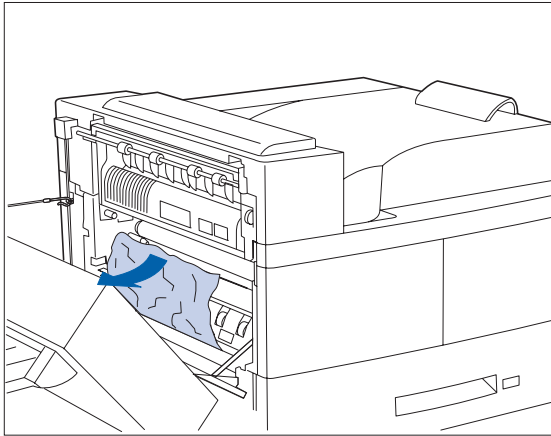

C If the paper jammed in Area A is below the Fuser, remove it by pulling it away from the printer.

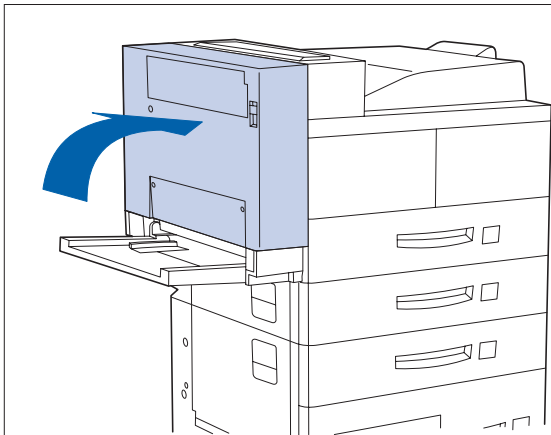

4 Close Door A, then close the Duplex Module.

 If the Control Panel message indicates an Area B jam, continue to the section “Clearing Area B” (page 5-12).

Clearing Area B

Follow the procedure below to clear a paper jam from Area B of the printer when the Control Panel display reads **Clear Area B**.

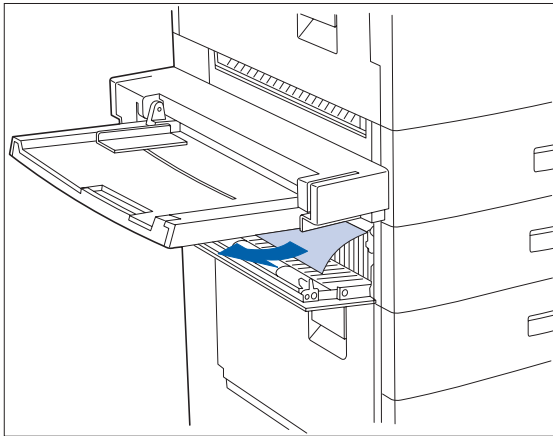

- 1 Open Door B and remove any jammed paper.**

 *For easier access to Door B, you can fold up the 50 Sheet Bypass Feeder (shown at left) or pull out the Envelope Feeder (if installed).*

- 2 Close Door B by pressing it in the middle.**

 *If the Control Panel message indicates an Area C jam, continue to the section “Clearing Area C” below.*

Clearing Area C

Follow the procedure below to clear a paper jam from Area C of the 2,500 Sheet Feeder when the Control Panel display reads **Clear Area C**.

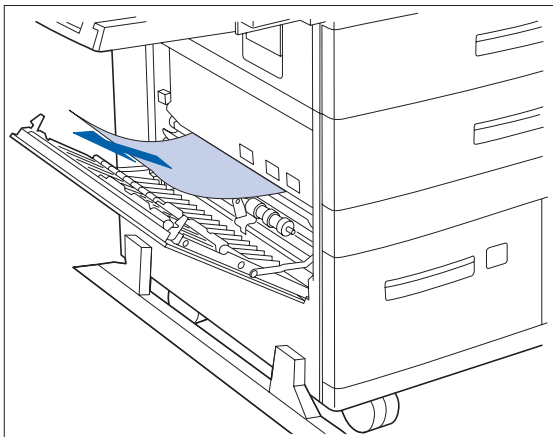

- 1 Open Door C and remove any jammed paper.**

- 2 Close Door C by pressing it in the middle.**

Clearing Area D

Follow the procedure below to clear a paper jam from Area D (Mailbox/Collator) when the Control Panel display reads **Clear Area D**.

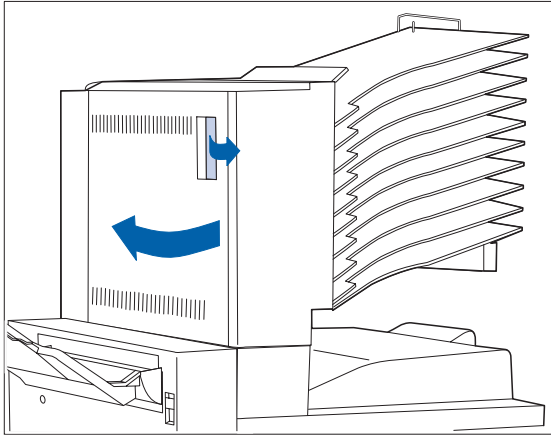

1 Open Door D.

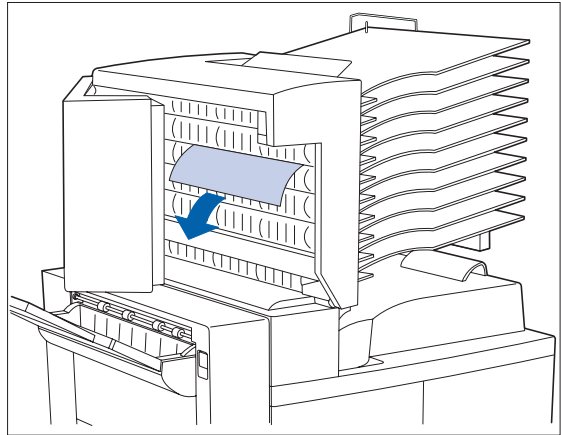

2 Remove any jammed paper.

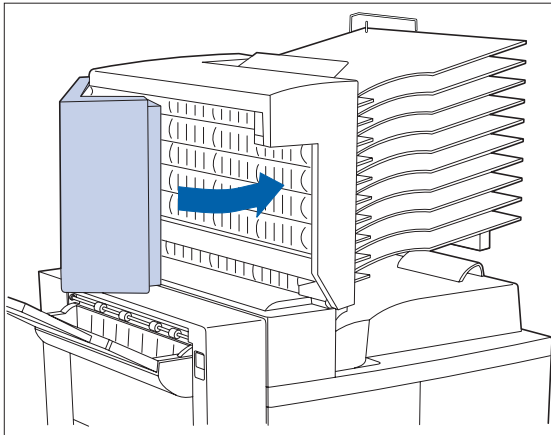

3 Close Door D.

Clearing Tray 5

Follow the procedure below to clear a paper jam from Tray 5 of the 2,500 Sheet Feeder when the Control Panel display reads **Reset Tray 5**.

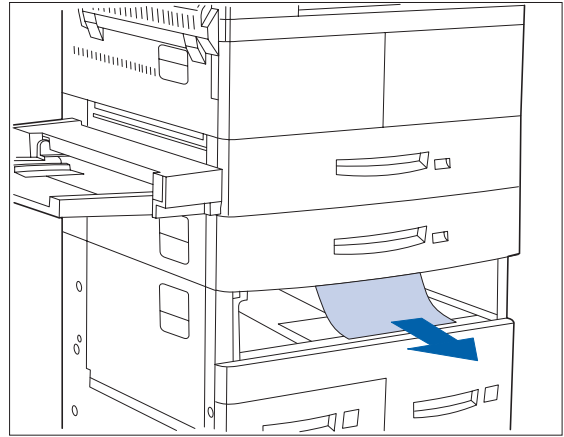
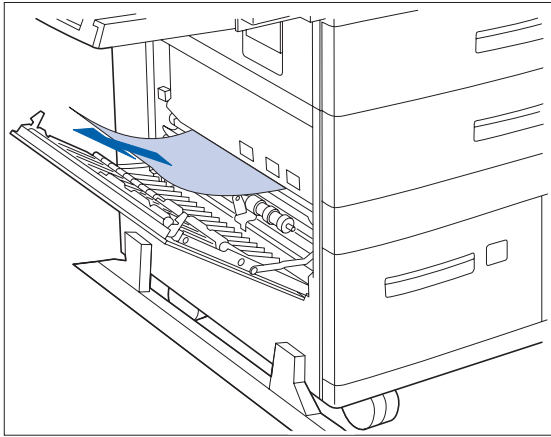

1 Open Door C and remove any jammed paper. Then close Door C.

2 Open and remove Tray 3 by lifting the tray from the front. Carefully pull out any jammed paper. Reseat the paper, then replace and close Tray 3.

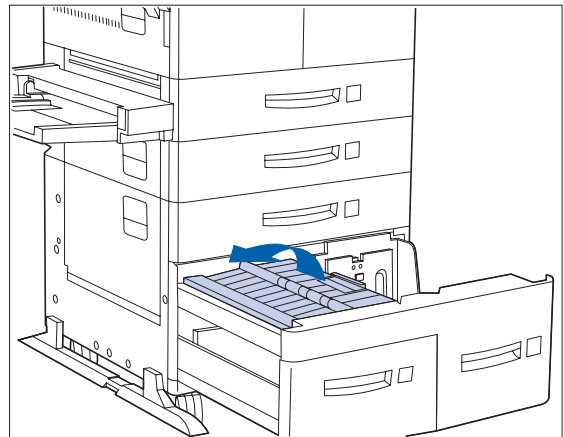
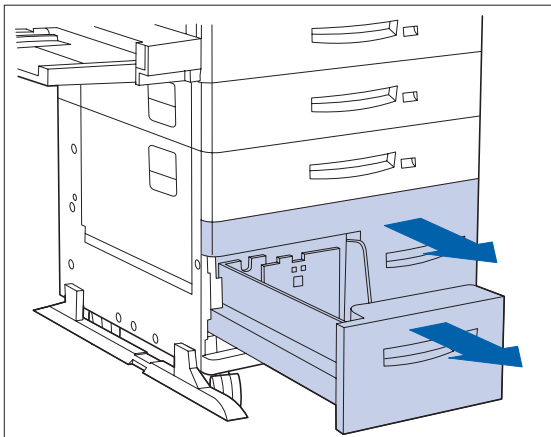

3 Open Trays 4 and 5. Carefully remove any jammed paper. Reseat the paper in the trays.

4 Lift the Tray 5 transport and carefully remove any jammed paper, then close Trays 4 and 5.

Clearing the Duplex Module

Follow the procedure below to clear a paper jam from the Duplex Module when the Control Panel display reads **Clear Duplex Unit**.

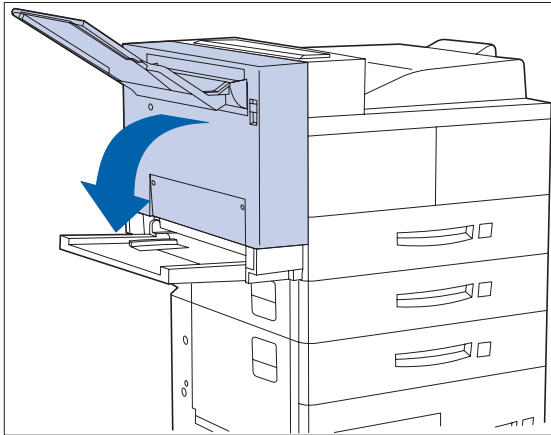

1 Open the Duplex Module.

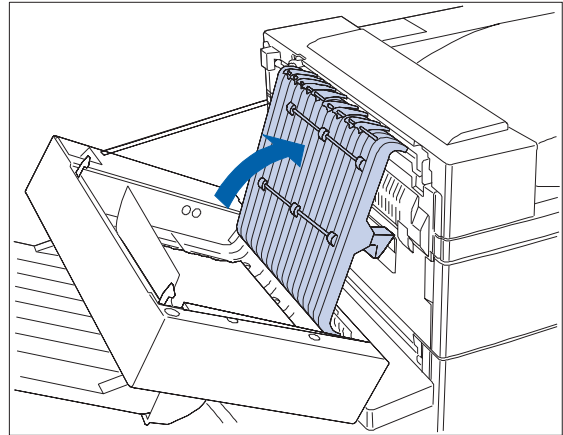

2 Open the inside cover of the Duplex Module.

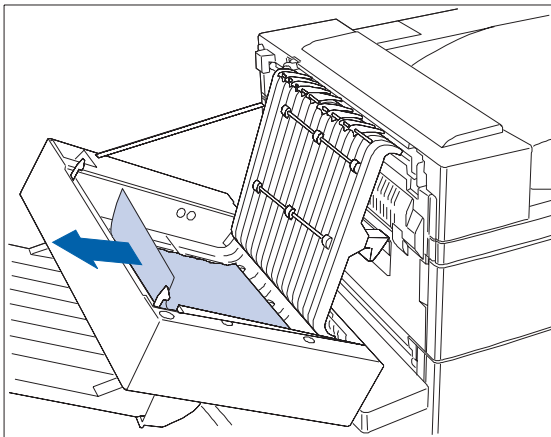

3 Remove any jammed paper in the direction of the arrow.

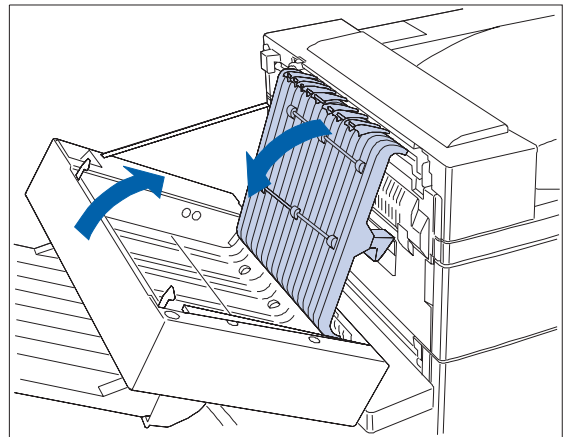

4 Close the inside cover of the Duplex Module, then close the Duplex Module.



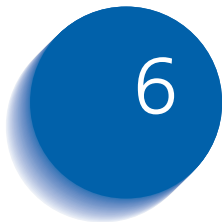

Replacing Your Toner Cartridge

<i>Replacing the Toner Cartridge</i>	6-2
<i>Standard Configuration</i>	6-3
<i>Duplex Configuration</i>	6-6
<i>About the Maintenance Kit</i>	6-9

Replacing the Toner Cartridge

This section describes how to replace the DocuPrint N40 Toner Cartridge in both a standard configuration printer and a printer with a Duplex Module attached.



- Do not expose the Toner Cartridge to direct sunlight or artificial light for more than 15 minutes. Overexposure will permanently damage the photosensitive imaging drum.
 - Do not open the drum shutter or touch the green imaging drum surface.
 - Be sure to shake the Toner Cartridge as directed to distribute the toner inside the cartridge. Print quality may be degraded if the toner is not evenly distributed. If the toner has not been properly freed by shaking the cartridge, you may hear a noise when powering on the printer, and the Toner Cartridge may be damaged.
 - Never touch the Fuser area inside the printer (where a label indicates high temperature).
-

If your printer does not have a Duplex Module installed, go to the section “*Standard Configuration*” (page 6-3).

If your printer has the Duplex Module installed, go to the section “*Duplex Configuration*” (page 6-6).

Instructions for replacing the Toner Cartridge are also available on a label on the back of the left front cover of the printer and in the Toner Cartridge box.

Standard Configuration

Follow this procedure to replace the Toner Cartridge on a standard configuration printer.

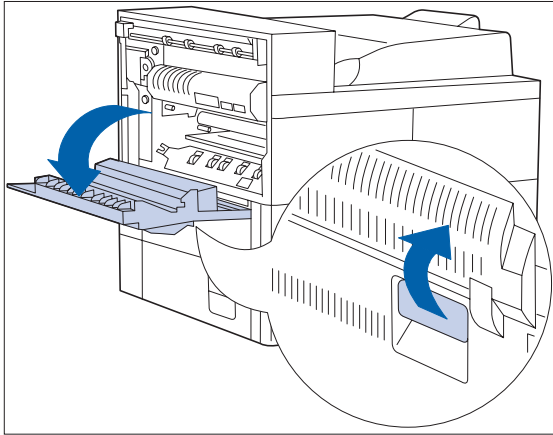

1 Open Door A.

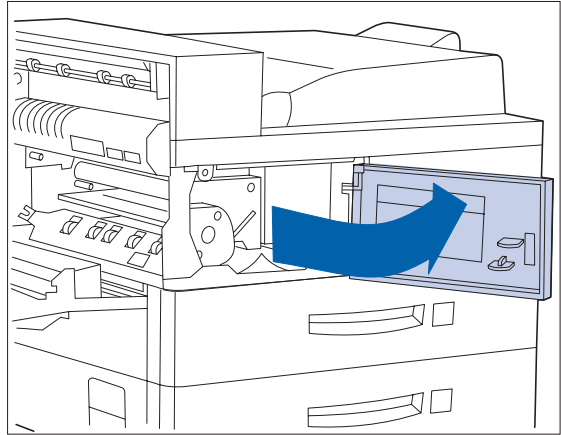

2 Open the front cover (which is spring loaded; you must hold it open or else it will shut).

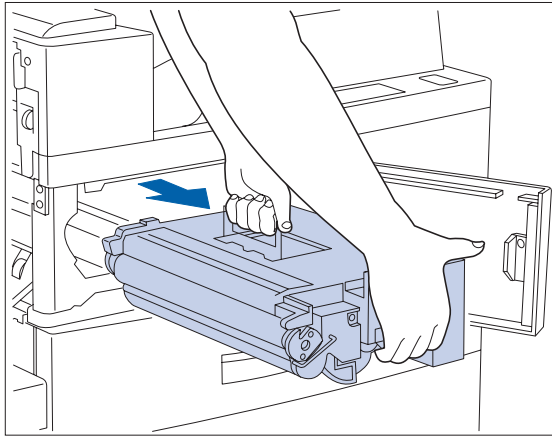

- 3** Remove the Toner Cartridge by lifting the amber handle and gently pulling it out.

Wrap the used Toner Cartridge in its original packing and return it as per directions in the packaging.

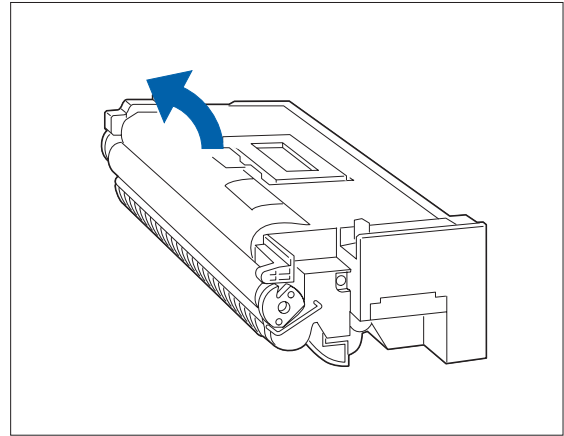

- 4** Remove the new Toner Cartridge from its package and pull out the protective paper sheet from the drum shutter.

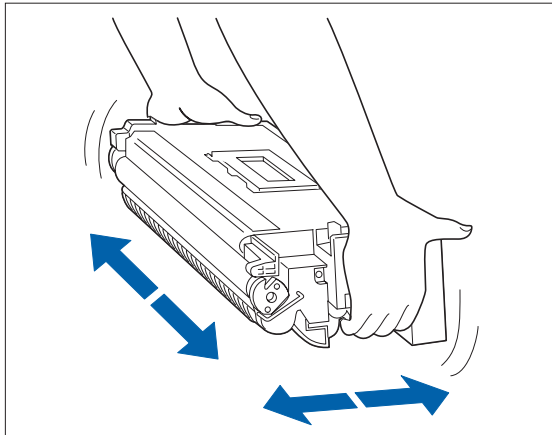

- 5** Hold the Toner Cartridge horizontally and gently shake it 5 to 6 times to evenly distribute the toner inside.

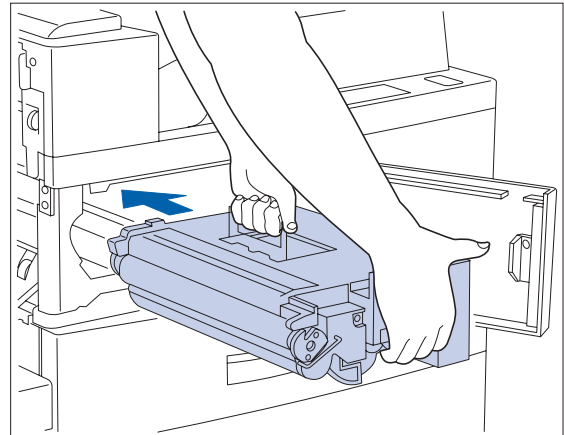

- 6** Hold the amber handle with one hand and gently push the Toner Cartridge all the way into the printer.

 Do not touch any parts inside the printer. Make sure the cartridge is firmly seated in the printer.

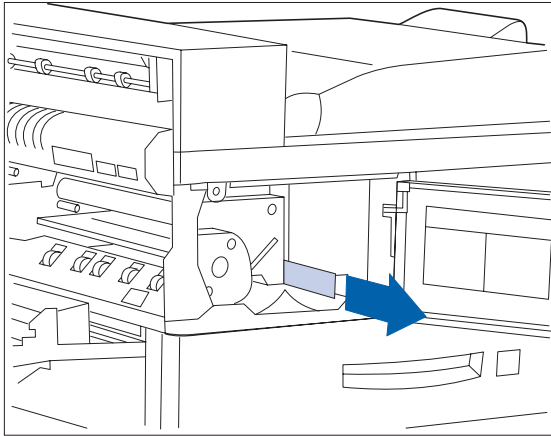

7 Gently pull the sealing tape straight out in the direction of the arrow.

 If the tape is pulled out at an angle, it may break.

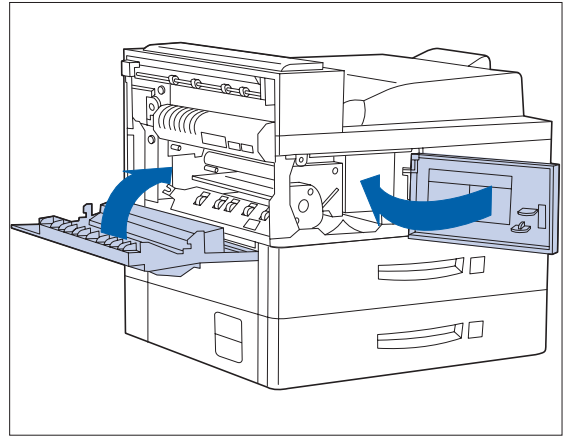

8 Close the front cover and Door A.

 When closing Door A, follow the instruction label on the door for the correct location at which to push the door closed.

Duplex Configuration

Follow this procedure to replace the Toner Cartridge on a printer with the Duplex Module installed.

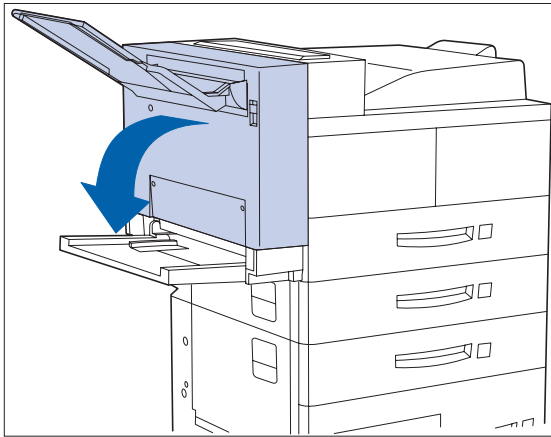

- 1** Open the Duplex Module by pulling on its latch.

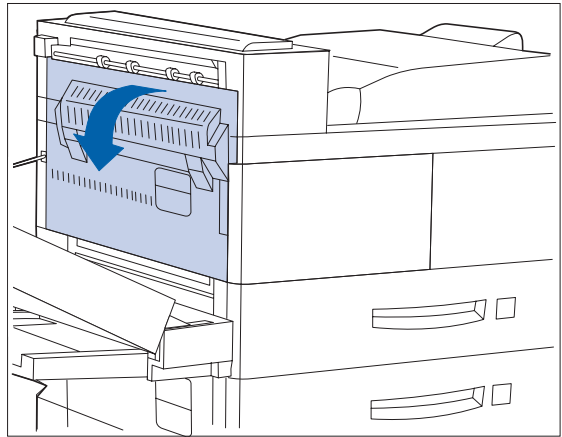

- 2** Open Door A.

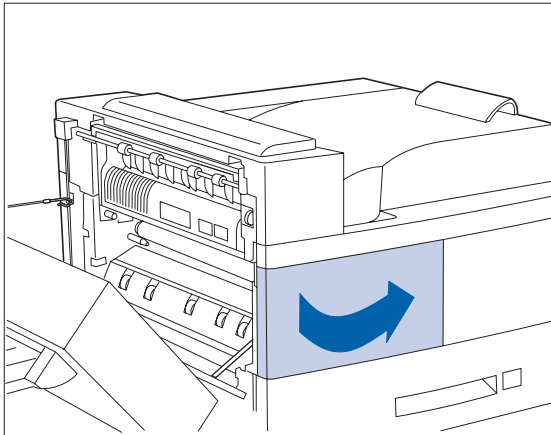

- 3** Open the front cover.

 *The printer's front cover is spring loaded and will not stay open. You must hold it open or else it will shut.*

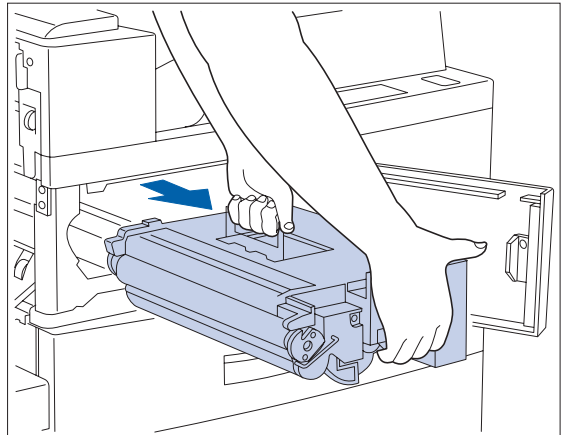

- 4** Remove the Toner Cartridge by lifting the amber handle and gently pulling it out.

Wrap the used Toner Cartridge in its original packing and return it as per directions on the packaging.

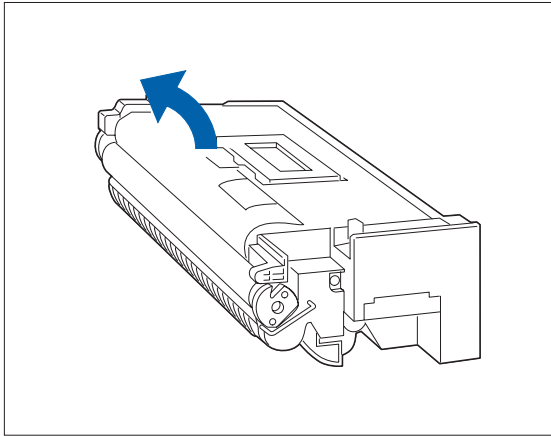

5 Remove the new Toner Cartridge from its package and pull out the protective paper sheet from the drum shutter.

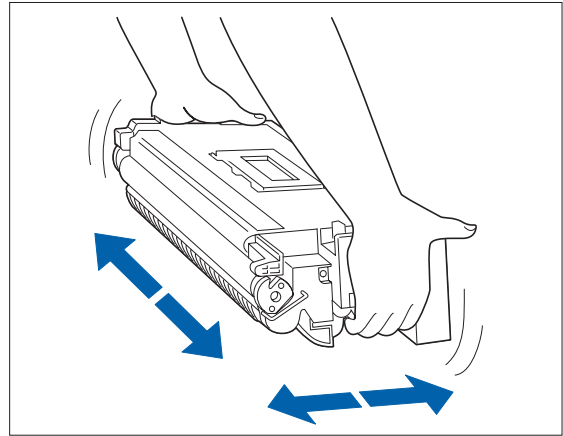

6 Hold the Toner Cartridge horizontally and gently shake it 5 to 6 times to evenly distribute the toner inside.

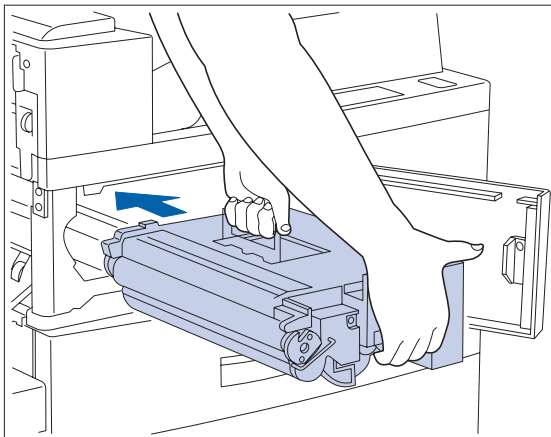

7 Hold the amber handle with one hand and gently push the Toner Cartridge all the way into the printer.

! Do not touch any parts inside the printer. Make sure the cartridge is firmly seated in the printer.

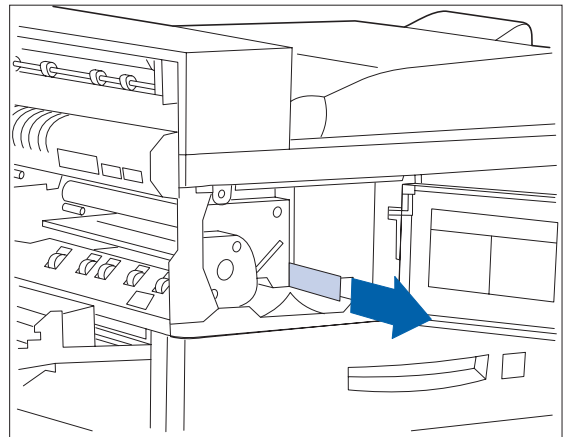

8 Gently pull the sealing tape straight out in the direction of the arrow.

! If the tape is pulled out at an angle, it may break.

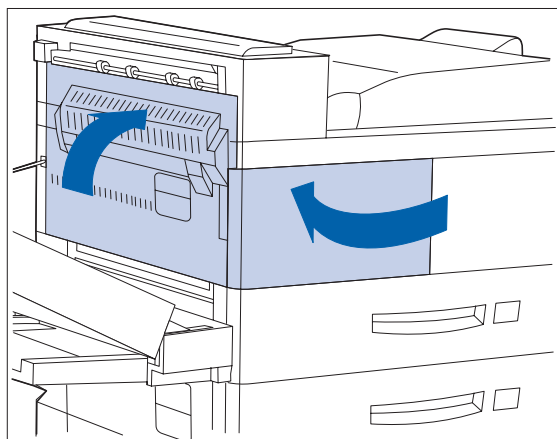

9 Close the front cover and Door A.

! When closing Door A, do not use the latch on the cover. Instead, follow the instruction label on the cover for the correct location at which to push the cover closed.

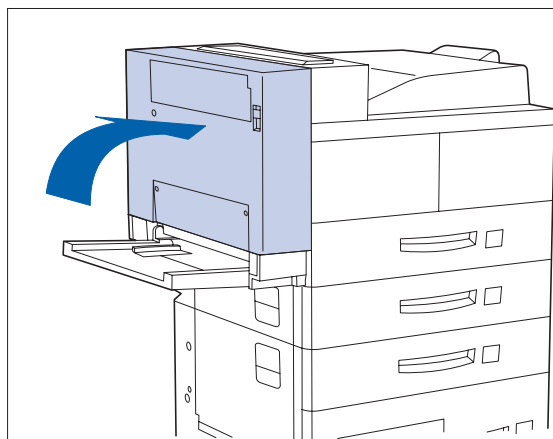

10 Close the Duplex Module.

About the Maintenance Kit

The DocuPrint N40 also has a Maintenance Kit which is customer installable. This kit should be installed after every 300,000 impressions. You will be told by a message on the Display when to install this kit. Instructions for installing this kit are in Appendix B of the DocuPrint N40 System Administrator Guide.

The Maintenance Kit is comprised of three items:

- Fuser Cartridge
- Bias Transfer Roll (BTR)
- 15 feedrolls (three for each paper input tray)

The Fuser Cartridge, feedrolls and BTR have expected useful lives of 300,000 impressions. Although printing can continue, to ensure optimum print quality you should order and replace these parts as soon as possible.





Troubleshooting

Diagnostic Message Display 7-2
Printer Operation Problems 7-3

Diagnostic Message Display

Chapter 6 of the DocuPrint N40 System Administrator Guide contains the entire set of messages which can appear on the DocuPrint N40 Control Panel display. Many of these messages are diagnostic messages which appear when there is a problem with the DocuPrint N40.

Chapter 6 of the DocuPrint N40 System Administrator Guide also contains a discussion of Print Quality symptoms and possible corrective actions.

If you have a problem with your DocuPrint N40 printer, and you cannot solve the problem using the actions suggested in Table 7.1 on page 7-3 of this guide, consult Chapter 6 of the DocuPrint N40 System Administrator Guide.

Printer Operation Problems

Consult Table 7.1 for corrective actions when the printer will not print or when the printed output is not what you expect.

Table 7.1 Printer operation problems

Problem	Action
<p>The printer will not print at all, or a file sent from the client/server will not print.</p>	<ol style="list-style-type: none"> 1. Check with your network administrator to see that the printer is powered up, connected to the network, and that the network is operational. 2. Check Control Panel messages for "Paper Jam," "Door Open," etc. 3. If the port (parallel or network) the printer is connected to is disabled, enable it. Check the Configuration Sheet for the port you are using to see if the Port Enable item in the appropriate Interface Menu is set to <i>On</i>. If it is set to <i>Off</i>, set it to <i>On</i> and try again. 4. If the printer has printed recently, do the following: <ul style="list-style-type: none"> - Attempt to print a Configuration Sheet. If it does not print, contact your dealer or Xerox. - If the Configuration Sheet prints, check to see that the printer is configured properly. - If the printer is configured properly, check the Configuration Sheet to confirm that the correct emulation is <i>On</i>. - If the correct emulation is <i>On</i> and the printer continues not to print, contact your dealer or Xerox.

Table 7.1 Page 1 of 3

Table 7.1 Printer operation problems *(continued)*

Problem	Action
<p>A printed page does not look like it should.</p>	<ol style="list-style-type: none"> 1. Make certain that the software application you are using to create your print job is configured properly. Refer to your software documentation. 2. Make sure the correct driver is being used. 3. Send a file containing PCL or PostScript commands to the printer. <ul style="list-style-type: none"> - If your page prints as it should, your printer and interface are functioning properly. - If your information prints correctly, but doesn't look right, you may have: <ul style="list-style-type: none"> - An error in your command sequence/operator. - A missing downloaded font. - A mismatched printer option against your host formatting. - Command errors may be identified by looking at your input file. You can determine which fonts are in the system by printing a PCL or PS Font List. You can verify your data setup by printing a Configuration Sheet and checking your printer setup.
<p>The requested font for the job does not print.</p>	<p>Print a PCL Font List, or PostScript Font List if the job is PostScript.</p> <ul style="list-style-type: none"> • If fonts print on the Font List, your print job may need correcting. • If fonts do not print on the Font List, reload the fonts and print another PCL or PostScript Font List.

Table 7.1 Page 2 of 3

Table 7.1 Printer operation problems (continued)

Problem	Action
PostScript commands are printed instead of the PostScript job.	<ol style="list-style-type: none"> 1. Make certain that the software application you are using to create your job is configured properly. Refer to your software documentation. 2. The job sent to the printer might have included an incorrect header, and therefore not have indicated that a PostScript job was being sent. <ul style="list-style-type: none"> - Check your software to make sure the PostScript header file is being sent to the printer. 3. Set the Print Errors item in the PostScript Menu to <i>On</i> and resend the job. <ul style="list-style-type: none"> - If an error page prints, there is a problem in the PostScript coding. Correct the coding problem and resend the job. - If the job still does not print and an error page was not printed, the job may require additional memory.
A PostScript or PCL job fails to print.	<ol style="list-style-type: none"> 1. Check that PostScript is installed; also check that you are using a DocuPrint N32 PostScript printer driver. 2. For a PostScript job, set the Print Errors item in the PostScript Menu to <i>On</i> and resend the job. <ul style="list-style-type: none"> - If an error page prints, there is a problem in the PostScript coding. Correct the coding problem and resend the job. - If the job still does not print and an error page was not printed, the job may require additional memory. 3. For a PCL job, do the following: <ul style="list-style-type: none"> - Check the output for PCL errors. - If there is a problem in the PCL coding, correct the coding problem and resend the job. - If there is no error message, resend the job. - If the job still does not print, the job may require additional memory.

Table 7.1 Page 3 of 3

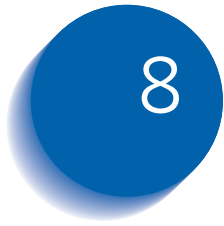

References

Further References

If you need further information over and above what is contained in this Guide, please consult the areas indicated in the following references:

- **Maintenance of the DocuPrint N40**

Chapter 1 and Appendix B of the DocuPrint N40 System Administrator Guide

- **Special DocuPrint N40 Features and Options**

Chapter 1 of the DocuPrint N40 System Administrator Guide

- **Memory Considerations**

Chapter 1 of the DocuPrint N40 System Administrator Guide

- **Extended Paper Handling Capabilities**

Chapter 2 of the DocuPrint N40 System Administrator Guide

- **Use of the DocuPrint N40 Optional Hard Disk Drive and Flash SIMMs**

Chapter 5 of the DocuPrint N40 System Administrator Guide

- **DocuPrint N40 Ordering Information**

Appendix A of the DocuPrint N40 System Administrator Guide

- **DocuPrint N40 Resident Fonts**

Appendix D of the DocuPrint N40 System Administrator Guide

- **Printer Specifications**
Appendix E of the DocuPrint N40 System Administrator Guide
- **DocuPrint N40 Unique Printer Commands**
Appendix F of the DocuPrint N40 System Administrator Guide
- **DocuPrint N40 Environmental Specifics including Safety**
Appendix G of the DocuPrint N40 System Administrator Guide
- **More Detailed Network/Environment Technical Information**
The DocuPrint N40 Technical Information Guide (on the N40 CD)
- **DocuPrint N40 Support Information**
The DocuPrint N40 Support Brochure or your warranty booklet
- **Network Installation Information**
The DocuPrint N40 Quick Network Installation Guide
- **DocuPrint N40 CentreWare Information**
The DocuPrint N40 CentreWare DP Users Guide (on the Printer Management Software CD)
- **DocuPrint N40 System Administrator Guide** (on the N40 CD)
- **Translated Versions of the DocuPrint N40 User Documentation** (on the N40 CD)



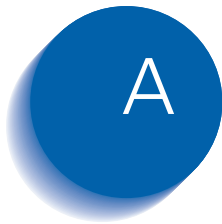

CE Declaration

This Appendix contains the “CE Declaration” which only applies to European Countries.

CE ENGLISH

The CE marking applied to this product symbolises Xerox's declaration of conformity with the following applicable directives of the European Union as of the dates indicated.

January 1, 1995 - Council Directive 73/23/EEC amended by Council Directive 93/68/EEC, Approximation of the laws of the member states related to low voltage equipment.

January 1, 1996 - Council Directive 89/336/EEC, Approximation of the laws of the member states related to electromagnetic compatibility.

A full declaration defining the relevant directives and referenced standards can be obtained from your Xerox representative.

WARNING: In order to allow this equipment to operate in proximity to Industrial, Scientific and Medical (ISM) equipment, the external radiation from ISM equipment may have to be limited or special mitigation measures taken.

CE FRANÇAIS

LE SYMBOLE CE FIGURANT SUR CE PRODUIT EST GARANT DE LA CONFORMITE DU MATERIEL XEROX AUX DIRECTIVES DE L'UNION EUROPEENNE ENTRANT EN VIGEUR AUX DATES INDIQUEES.

1er JANVIER 1995 : - Directive du Conseil du 19 février 1973 numéro 73/23/CEE concernant le rapprochement des législations des Etats membres relatives au matériel électrique destiné à être employé dans certaines limites de tension.

1er JANVIER 1996 : - Directive du Conseil du 3 mai 1989 numéro 89/336/CEE concernant le rapprochement des législations des Etats membres relatives à la compatibilité électromagnétique.

LA GARANTIE DE CONFORMITE COMPLETE, AVEC UNE DESCRIPTION DETAILLEE DES DIRECTIVES ET NORMES CONCERNEES, PEUT ETRE OBTENUE SUR SIMPLE DEMANDE AUPRES DE VOTRE COMMERCIAL XEROX.

COMPATIBILITE ELECTROMAGNETIQUE AVERTISSEMENT : Afin de permettre à ce matériel de fonctionner à proximité de matériel ISM, il peut s'avérer nécessaire de réduire le rayonnement émis par ce dernier ou de prendre des mesures spéciales.

CE DEUTSCH

DURCH KENNZEICHNUNG DIESES PRODUKTES MIT DEM CE-ZEICHEN ERKLÄRT SICH XEROX BEREIT, DEN FOLGENDEN DIREKTIVEN DER EUROPÄISCHEN UNION ZU ENTSPRECHEN (MIT WIRKUNG VOM SIEHE DATUM):

1. Januar 1995: - EG-Direktive 73/23/EEC ergänzt durch EG-Direktive 93/68/EEC, Angleichung der Gesetze der einzelnen Mitgliedstaaten bezüglich Geräte mit niedriger Betriebsspannung.

1. Januar 1996: - EG-Direktive 89/336/EEC, Angleichung der Gesetze der einzelnen Mitgliedstaaten bezüglich elektromagnetischer Kompatibilität.

Den vollständigen Text dieser Erklärung einschließlich der Definition der entsprechenden Direktiven sowie der jeweiligen Standards erhalten Sie von Ihrem Xerox Kundendienst.

ELEKTROMAGNETISCHE VERTRÄGLICHKEIT - ACHTUNG: Um eine fehlerfreie Funktion dieses Gerätes in der Umgebung von ISM-Geräten (Hochfrequenzgeräte für industrielle, wissenschaftliche, medizinische und ähnliche Zwecke) zu gewährleisten, ist es erforderlich, daß die Störstrahlung dieser Geräte reduziert oder auf andere Weise begrenzt wird.

CE PORTUGUES

A MARCA CE USADA NESTE PRODUTO, SIMBOLIZA A DECLARAÇÃO DE CONFORMIDADE DA XEROX, COM AS SEGUINTEs DIRECTIVAS APLICAVEIS DA UNIAO EUROPELA AQUANDO DAS DATAS INDICADAS

1 DE JANEIRO DE 1995:- Directiva 73/23/CEE do Conselho, de 19 de Fevereiro de 1973, relativa à harmonização das legislações dos Estados membros no domínio do material eléctrico destinado a ser utilizado dentro de certos limites de tensão.

1 DE JANEIRO DE 1996:- Directiva 89/336/CEE do Conselho, de 3 de Maio de 1989, relativa à aproximação das legislações dos Estados-membros respeitantes à compatibilidade electromagnética.

Pode pedir ao seu representante Xerox, uma declaração integral definindo as directivas relevantes e padrões referenciados.

COMPATIBILIDADE ELECTROMAGNÉTICA ATENÇÃO: De modo a permitir que este equipamento funcione perto de um equipamento ISM, a adição externa do equipamento ISM poderá ter que ser limitada ou serem tomadas medidas especiais de mitigação.

CE ITALIANO

IL MARCHIO CE APPLICATO A QUESTO PRODOTTO, EQUIVALE A UNA DICHIARAZIONE DI CONFORMITÀ DA PARTE DELLA XEROX RISPETTO ALLE SEGUENTI DIRETTIVE EMESSE DALLA UNIONE EUROPEA ALLE DATE SOTTOINDICATE.

1 GENNAIO 1995: La direttiva 73/23/CEE del Consiglio, del 19 febbraio 1973, concernente il ravvicinamento delle legislazioni degli Stati membri relative al materiale elettrico destinato ad essere adoperato entro taluni limiti di tensione.

1 GENNAIO 1996: La direttiva 89/336/CEE del Consiglio, del 3 maggio 1989, per il ravvicinamento delle legislazioni degli Stati membri relative alla compatibilità elettromagnetica.

LA DICHIARAZIONE COMPLETA, RIPORTANTE LE DIRETTIVE PERTINENTI E GLI STANDARD IVI MENZIONATI, PUÒ ESSERE OTTENUTA PRESSO IL FORNITORE XEROX DI ZONA.

COMPATIBILITÀ ELETTROMAGNETICA AVVERTENZA: Il funzionamento di questo apparecchio in prossimità di apparecchiature ISM rende necessaria la riduzione o la limitazione delle radiazioni emesse da dette apparecchiature.

CE SVENSKA

Ce-märkningarna som finns på denna produkt visar Xerox deklARATION VAD GÄLLER ÖVERENSSTÄMMELSE MED DE DIREKTIV SOM ANGETTS AV DEN EUROPEISKA UNIONEN.

1 januari 1995:- eu-direktiv 73/23/eec tillägg till eu-direktiv 93/68/eec, vad gäller närmanden av medlemsländernas lagar beträffande lågspänningstrustning.

1 januari 1996:- eu-direktiv 89/336/eec, vad gäller närmanden av medlemsländernas lagar beträffande elektromagnetisk kompatibilitet.

Ytterligare beskrivning och definiering av relevanta direktiv och refererade standarder kan erhållas från er Xerox-representant.

ELEKTROMAGNETISK KOMPATIBILITET VARNING: För att denna utrustning ska få arbeta i närheten av en ISM-utrustning så måste den externa strålningen från ISM-utrustningen avgränsas eller nedsättas.

CE HOLLANDS

HET CE-STEMPEL OP DIT PRODUKT SYMBOLISEERT DE CONFORMITEITSVERKLARING VAN XEROX MET DE VOLGENDE VAN TOEPASSING ZIJNDE RICHTLIJNEN VAN DE EU VANAF DE AANGEGEVEN DATA.

1 JANUARI, 1995:- Richtlijn 73/23/EEG van de Raad van 19 februari 1973 betreffende de onderlinge aanpassing van de wettelijke voorschriften der Lid-Staten inzake elektrisch materiaal bestemd voor gebruik binnen bepaalde spanningsgrenzen.

1 JANUARI, 1996:- Richtlijn 89/336/EEG van de Raad van 3 mei 1989 betreffende de onderlinge aanpassing van de wetgevingen van de Lid-Staten inzake de elektromagnetische compatibiliteit.

DE VOLLEDIGE TEKST VAN DEZE VERKLARING, WAARIN DEFINITIES VAN DE RELEVANTE RICHTLIJNEN EN DE RELEVANTE NORMEN, KAN WORDEN VERKREGEN BIJ UW XEROX-LEVERANCIER.

ELEKTROMAGNETISCHE COMPATIBILITEIT
WAARSCHUWING: Om dit apparaat in de nabijheid van industriële, wetenschappelijke en medische (ISM)-apparatuur te laten functioneren, kan het nodig zijn de stoorstraling komende van de ISM-apparatuur te beperken of speciale maatregelen te treffen met het oog op het terugdringen hiervan.

CE ESPAÑOL

EL SÍMBOLO DE LA CE APLICADO A ESTE PRODUCTO SIGNIFICA LA DECLARACIÓN DE XEROX DEL CUMPLIMIENTO DE LAS SIGUIENTES DIRECTIVAS APLICABLES DE LA UNIÓN EUROPEA A PARTIR DE LAS FECHAS INDICADAS.

1 ENERO, 1995:- Directiva 73/23/CEE del Consejo, de 19 de febrero de 1973 (LCEur 1973, 48), sobre el material eléctrico destinado a utilizarse con determinados límites de tensión.

1 ENERO, 1996:- Directiva 89/336/CEE del Consejo, de 3 de mayo de 1989 (LCEur 1989, 628), sobre la aproximación de las legislaciones de los Estados miembros relativas a la compatibilidad electromagnética.

SE PUEDE OBTENER UNA AFIRMACIÓN COMPLETA CON LA DEFINICIÓN DE LAS DIRECTIVAS PERINENETES Y LAS NORMAS DE REFERENCIA PONIÉNDOSE EN CONTACTO CON EL DELEGADO DE XEROX.

COMPATIBILIDAD ELECTROMAGNÉTICA AVISO: Para que este equipo funcione en las inmediaciones de un equipo ISM, tal vez sea preciso limitar la radiación externa del equipo ISM, o adoptar medidas de mitigación especiales.

CE ΕΛΛΗΝΙΚΑ

ΤΟ ΣΥΜΒΟΛΟ CE ΠΟΥ ΥΠΑΡΧΕΙ ΣΕ ΑΥΤΟ ΤΟ ΠΡΟΙΟΝ, ΣΥΜΒΟΛΙΖΕΙ ΤΗ ΔΗΛΩΣΗ ΤΗΣ RANK XEROX ΟΤΙ ΣΥΜΜΟΡΦΟΥΤΑΙ ΜΕ ΤΙΣ ΟΔΗΓΙΕΣ ΤΗΣ ΕΥΡΩΠΑΙΚΗΣ ΕΝΩΣΗΣ ΩΣ ΠΡΟΣ ΤΙΣ ΚΑΤΩΘΙ ΗΜΕΡΟΜΗΝΙΕΣ.

1 ΙΑΝΟΥΑΡΙΟΥ 1995:- ΟΔΗΓΙΑ Νο 73/23/ΕΕΚ ΤΡΟΠΟΠΟΙΗΜΕΝΗ ΑΠΟ ΤΗΝ ΟΔΗΓΙΑ 93/68/ΕΕΚ, ΠΕΡΙ ΣΥΜΜΟΡΦΩΣΗΣ ΜΕ ΤΟΥΣ ΝΟΜΟΥΣ ΤΩΝ ΚΡΑΤΩΝ ΜΕΛΩΝ ΣΧΕΤΙΚΑ ΜΕ ΜΗΧΑΝΗΜΑΤΑ ΧΑΜΗΛΗΣ ΤΑΣΗΣ.

1 ΙΑΝΟΥΑΡΙΟΥ 1996:- ΟΔΗΓΙΑ Νο 89/336/ΕΕΚ, ΠΕΡΙ ΣΥΜΜΟΡΦΩΣΗΣ ΜΕ ΤΟΥΣ ΝΟΜΟΥΣ ΤΩΝ ΚΡΑΤΩΝ ΜΕΛΩΝ ΣΧΕΤΙΚΑ ΜΕ ΤΗΝ ΗΛΕΚΤΡΟΜΑΓΝΗΤΙΚΗ ΣΥΜΒΑΤΟΤΗΤΑ.

ΜΙΑ ΠΛΗΡΗΣ ΔΙΑΚΗΡΥΞΗ ΠΟΥ ΚΑΘΟΡΙΖΕΙ ΤΙΣ ΣΧΕΤΙΚΕΣ ΔΙΑΤΑΞΕΙΣ ΚΑΙΤΑ ΣΧΕΤΙΚΑ ΠΡΟΤΥΠΑ ΜΠΟΡΕΙ ΝΑ ΖΗΤΗΘΕΙ ΑΠΟ ΤΟΝ ΑΝΤΙΠΡΟΣΩΠΟ ΤΗΣ RANK XEROX.

ΕΛΕΚΤΡΟΜΑΓΝΗΤΙΚΗ ΣΥΜΒΑΤΟΤΗΤΑ ΠΡΟΣΟΧΗ: Για να επιτραπεί η λειτουργία του μηχανήματος άσει των προδιαγραφών ISM, η εκπομπή ραδιοσυχνοτήτων θα πρέπει να μειωθεί ή να παρθούν ειδικά μέτρα περιορισμού της.

CE SUOMI

Tässä tuotteessa oleva CE- eli vaatimustenmukaisuusmerkintä osoittaa, että Xerox on sitoutunut noudattamaan seuraavia EU-direktiivejä mainitusta päivämäärästä lähtien.

Tammikuun 1. päivä, 1995: Neuvoston direktiivi 73/23/ETY ja sen muutos 93/68/ETY tietyllä jänniteluella toimivia sähkölaitteita koskevan jäsenvaltioiden lainsäädännön lähentämistä.

Tammikuun 1. päivä, 1995:- Neuvoston direktiivi 89/336/ETY sähkömagneettista yhteensopivuutta koskevan jäsenvaltioiden lainsäädännön lähentämistä.

Täydelliset tiedot asianomaisista direktiiveistä ja standardeista on saatavissa Xeroxilta.

SÄHKÖMAGNEETTINEN YHTEENSOPIVUUS VAROITUS: Jotta tämä laite voisi toimia ISM-laitteen (teolliset, tieteelliset ja lääketieteelliset laitteet) läheisyydessä, ISM-laitteen ulkoista säteilyä pitää ehkä rajoittaa tai lieventäviä erikoistoimia toteuttaa.

CE DANSK

CE MÆRKET ANGIVER, AT DETTE XEROX PRODUKT OPFYLDER KRAVENE I NEDENSTÅENDE EF DIREKTIVER AF NÆVNTE DATOER.

1. JANUAR 1995:- Rådets direktiv 73/23/EOF af 19. februar 1973 om tilnærmelse af medlemsstaternes lovgivning om elektrisk materiel bestemt til anvendelse inden for visse spændingsgrænser.

1. JANUAR 1996:- Rådets direktiv 89/336/EOF af 3. maj 1989 om indbyrdes tilnærmelse af medlemsstaternes lovgivning om elektromagnetisk kompatibilitet.

RING TIL XEROX TEKNISK SERVICE, HVIS DE ØNSKER EN LISTE OVER RELEVANTE EF DIREKTIVER OG STANDARDER.

ELEKTROMAGNETISK KOMPATIBILITET ADVARSEL: For at dette udstyr kan anvendes i umiddelbar nærhed af ISM udstyr, skal udstrålingen fra ISM udstyr begrænses eller der skal laves specielle begrænsende anordninger.





Index

Numerics

- 100 Envelope Feeder
 - Capacity 4-4
 - Envelope orientation 4-18
 - Envelope sizes supported 4-4
 - Loading envelopes 4-19
 - Location on printer 1-8
- 10-bin Mailbox/Collator
 - Bin capacity 4-4
 - Location on printer 1-8
 - Paper sizes supported 4-4
- 2,500 Sheet Feeder
 - Location on printer 1-8
- 50 Sheet Bypass Feeder
 - Capacity 4-4
 - Loading 4-14 to 4-18
 - Location on printer 1-7
 - Paper orientation 4-16 to 4-18
 - Paper sizes supported 4-4

A

- A3 size paper
 - Dimensions 4-4
 - Supported trays/bins 4-4
- A4 size paper
 - Dimensions 4-4
 - Supported trays/bins 4-4

- A5 size paper
 - Dimensions 4-4
 - Supported trays/bins 4-4
- A6 size paper
 - Dimensions 4-4
 - Supported trays/bins 4-4

B

- Bias Transfer Roll (BTR)
 - Also see* Maintenance Kit
 - Location in printer 1-8
- Bins
 - Face-down Bin
 - See* Face-down Bin
 - Face-up Bin
 - See* Face-up Bin
 - Mailbox
 - See* 10-bin Mailbox/
Collator

C

- C5 size envelopes
 - Dimensions 4-4
 - Supported trays/bins 4-4
- CentreWare DP
 - Description 2-2
 - Features 2-2
- Com10 size envelopes

- Dimensions 4-4
- Supported trays/bins 4-4
- Control Panel 3-2 to 3-3
 - Display
 - Description 3-3
 - Location on printer 3-2
 - Indicator lights
 - Location on printer 3-2
 - Keys
 - Location on printer 3-2
 - Location on printer 1-7
- Controller Board
 - Location on printer 1-7

D

- DL size envelopes
 - Dimensions 4-4
 - Supported trays/bins 4-4
- DocuPrint N32
 - Components 1-7 to 1-8
- Drivers
 - See Drivers
 - Family of printers 1-2
 - Maintenance
 - Also see Maintenance Kit
 - Troubleshooting
 - See Troubleshooting
- Door A
 - Location on printer 1-7
- Door B
 - Location on printer 1-7
- Drivers
 - PCL emulation
 - Description 2-4
 - Features 2-6
 - PostScript
 - Description 2-5
 - Features 2-6
 - Usage
 - Setting duplex printing 4-22
- Duplex Module
 - Also see Duplex printing
 - Location on printer 1-8
- Duplex printing
 - Also see Duplex Module
 - Control Panel settings 4-23
 - Long edge feed

- Landscape orientation 4-23
- Portrait orientation 4-23
- Paper orientation
 - 50 Sheet Bypass Feeder 4-16, 4-17
 - Trays 1,2 and 3 4-9, 4-10
 - Trays 4 and 5 4-13
- Paper sizes supported 4-22
- Short edge feed
 - Landscape orientation 4-23
 - Portrait orientation 4-23

E

- Envelopes
 - Duplex printing 4-22
 - Loading in 100 Envelope Feeder 4-19
 - Loading in 50 Sheet Bypass Feeder 4-14
 - Orientation 4-18, 4-19
 - Sizes supported 4-4
- Executive size paper
 - Dimensions 4-4
 - Supported trays/bins 4-4

F

- Face-down Bin
 - Capacity 4-4
 - Location on printer 1-7
 - Paper sizes supported 4-4
- Face-up Bin
 - Capacity 4-4
 - Location on printer 1-7, 1-8
 - Paper sizes supported 4-4
- Feedrolls
 - Also see Maintenance Kit
 - Location in printer 1-8
- Folio size paper
 - Dimensions 4-4
 - Supported trays/bins 4-4
- Front cover
 - Location on printer 1-7
- Fuser/Fuser Cartridge
 - Also see Maintenance Kit
 - Location in printer 1-8

H

- Hand grips
 - Location on printer 1-7

L

Labels

- Sizes supported 4-4
- Supported Trays/Bins 4-4

Ledger size paper

- Dimensions 4-4
- Supported trays/bins 4-4

Legal size paper

- Dimensions 4-4
- Supported trays/bins 4-4

Letter size paper

- Dimensions 4-4
- Supported trays/bins 4-4

M

Maintenance Kit

- Bias Transfer Roll 6-9
- Description 6-9
- Feedrolls 6-9
- Fuser Cartridge 6-9

Monarch size envelopes

- Dimensions 4-4
- Supported trays/bins 4-4

O

Output bins

- Face-down Bin
 - See Face-down Bin
- Face-up Bin
 - See Face-up Bin
- Mailbox
 - See 10-bin Mailbox/Collator

P

Paper

- Jam removal
 - See Paper jams
- Jams
 - See Paper jams
- Loading 4-6 to 4-19
 - 50 Sheet Bypass Feeder 4-14 to 4-18
 - Tray 1 4-7 to 4-10
 - Tray 2 4-7 to 4-10
 - Tray 3 4-7 to 4-10
 - Tray 4 4-11 to 4-13
 - Tray 5 4-11 to 4-13

Orientation

50 Sheet Bypass Feeder 4-16 to 4-18

- Tray 1 4-9 to 4-10
- Tray 2 4-9 to 4-10
- Tray 3 4-9 to 4-10
- Tray 4 4-13
- Tray 5 4-13

Selecting for use 4-2

Sizes supported

- 10-bin Mailbox/Collator 4-4
- 50 Sheet Bypass Feeder 4-4
- Face-down Bin 4-4
- Face-up Bin 4-4
 - Tray 1 4-4
 - Tray 2 4-4
 - Tray 3 4-4
 - Tray 4 4-4
 - Tray 5 4-4

Storing 4-5

Unacceptable for use 4-2

Weights supported 4-2

Paper jams 5-2 to 5-15

Causes 5-2

Clearing 5-2 to 5-15

- From Area A (with Duplex Module) 5-9 to 5-11
- From Area A (without Duplex Module) 5-7 to 5-9
- From Area B 5-12
- From Area C 5-12
- From Area D 5-13
- From Duplex Module 5-15
- From Tray 5 5-14

Control Panel messages 5-3

Paper trays

- See Tray 1, Tray 2, Tray 3, Tray 4, Tray 5

PCL emulation

Drivers

- Description 2-4

PostScript

Drivers

- Description 2-5

Power receptacle

- Location on printer 1-7

Power switch

- Location on printer 1-7

Printer drivers

- See Drivers

S

Statement size paper

Dimensions 4-4

Supported trays/bins 4-4

T

Toner

Also see Toner Cartridge

Toner Cartridge

Location in printer 1-8

Recycling 6-4, 6-6

Replacing 6-2 to 6-8

With Duplex Module 6-6 to 6-8

Without Duplex Module 6-3 to 6-5

Transparencies

Sizes supported 4-4

Supported Trays/Bins 4-4

Tray 1

Capacity 4-4

Loading 4-7 to 4-10

Location on printer 1-7

Paper orientation 4-9 to 4-10

Paper sizes supported 4-4

Tray 2

Capacity 4-4

Loading 4-7 to 4-10

Location on printer 1-7

Paper orientation 4-9 to 4-10

Paper sizes supported 4-4

Tray 3

Capacity 4-4

Loading 4-7 to 4-10

Location on printer 1-8

Paper orientation 4-9 to 4-10

Paper sizes supported 4-4

Tray 4

Capacity 4-4

Loading 4-11 to 4-13

Location on printer 1-8

Paper orientation 4-13

Paper sizes supported 4-4

Tray 5

Capacity 4-4

Loading 4-11 to 4-13

Location on printer 1-8

Paper orientation 4-13

Paper sizes supported 4-4

Tray Sequence

Also see Tray switching

Tray switching

Also see Tray Sequence

Description 4-20 to 4-21

Paper size/type mismatch 4-21

Troubleshooting

Paper jams 5-2 to 5-15

Printer operation problems 7-3 to 7-5